

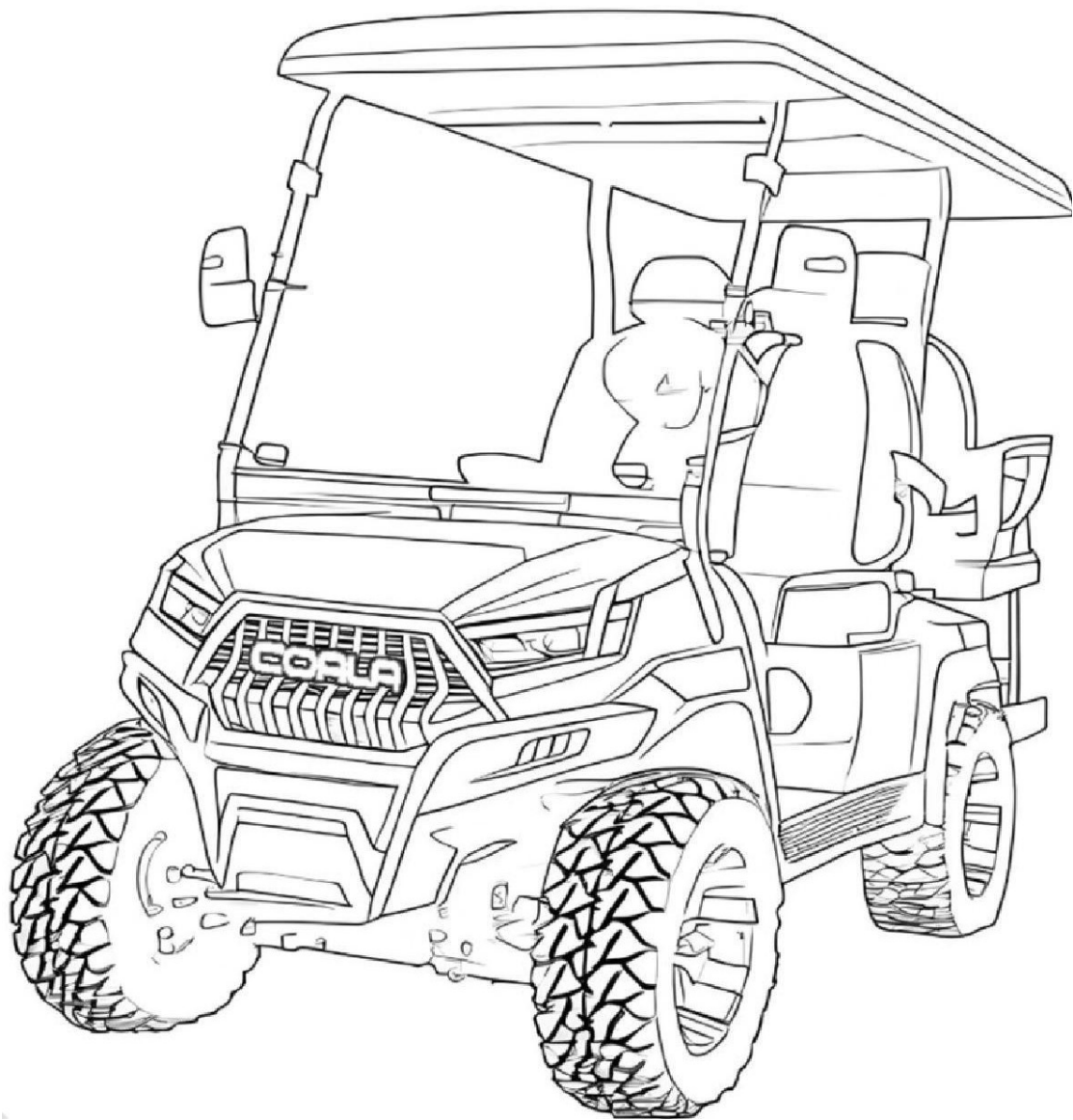

User's Manual Of



THANK YOU!

Thank you for choosing this vehicle. This User's Manual provides information on everything you need to know for your operation with COALA models.

This COALA's Manual contains important information that you will need for the proper operation and handling of your COALA Vehicle.

COALA is not liable for errors in this manual or for incidental or consequential damages that result from the use of the material in this manual. In order to insure all the information is correct, there may be changes to make according to improvements of the products at the time of printing, we reserve the rights to make corrections as well as product alterations and improvements at any time without notice. Trademarks are the property of COALA Electric Vehicles, Inc. or their respective owners.

Read this user's manual before starting off in your new COALA . It contains important information on the operation of your vehicle, entertainment ,storage and cooling systems that will help you make full use of the technical features they offer. Any updates made after the editorial deadline can be found in the appendix of the printed Owner's Manual for the vehicle. You can find supplementary information in the additional brochures in dealership show rooms .

Read all of this manual to become thoroughly familiar with this vehicle. Particularly important information is emphasized in this manual.

The use of non Original Equipment Manufacturer (OEM) approved parts may void the warranty.

Tampering with or adjusting the governor to permit vehicle to operate at above factory specifications will void the vehicle warranty.

USER'S MANUAL LITHIUM-ION BATTERY POWERED VEHICLE

B1

STARTING MODEL YEAR 2026

1. The COALA Electric vehicles known in this manual as the "COALA".
2. Unless otherwise stated, applicable low speed vehicle definitions and abbreviations are used throughout this document. Refer also to Golf Car Terminologies for additional definitions and abbreviations.
3. Appendices form part of, and have the same status as, these regulations
4. The editing practices used in this document are as follows:
 - (a) 'Shall' or 'Will' or 'Must' is used to indicate a mandatory requirement.
 - (b) 'Should' is used to indicate a recommendation.
- © 'May' is used to indicate discretion by COALA, the industry or the applicant, as appropriate.

Note: The use of the male gender implies all genders.

5. Paragraphs and sub-paragraphs with new, amended and corrected text will be enclosed within brackets until a subsequent "amendment" is issued.

TO CONTACT US

COALA ELECTRIC VEHICLES INC

Address: 9109 Santa Anita Ave, Rancho

Cucamonga, CA 91730

TEL: +1(626)988-6768

+1(949)696-7162

Email: cabaseoffice@gmail.com

www.drivecoala.com

TABLE OF CONTENTS

SAFETY INFORMATION1

Important Safety Information	1
Vehicle Safety Labels	2
Battery Safety Information	5
Lithium-Ion Battery Recycling	6

VEHICLE SERIAL NUMBER LOCATION7

Vehicle Serial & VIN Number	7
-----------------------------------	---

VEHICLE FEATURES8

Vehicle Overview.....	8
Dashboard.....	8
Rear Part Of Vehicle.....	9
Control Switches And Pedals.....	10

OPERATION AND CONTROLS12

Pre-Operation Safety And Performance Inspection	12
Start The Vehicle	15
Drive And Control	16
Turn Signals	17
Charging Ports.....	17
Lights Control	18
Adjusting the height of the steering column	18
Adding Brake Fluid	19
Rear View Mirror Folding.....	19

TOUCHSCREEN MANUAL20

Touchscreen Overview	20
Blue Tooth Connection	20
Radio.....	20
Video, Photo And Music.....	21
Set	21
Change Route Unit Between Miles And Km	21
System Versions	22
Change The Language	22
Change Location	22
Change Auto Play Mode	23
Others	24
Topmount Sound Bar	25

OPTIONAL ACCESSORIES.....	25
<hr/>	
GOLF BAG HOLDER	25
LITHIUM BATTERY.....	26
<hr/>	
Lithium Battery Introduction	26
BATTERY CHARGER	27
<hr/>	
Charger User Manual.....	27
WHEELS & TIRES	29
<hr/>	
LIFT AND LOWER THE VEHICLE	32
<hr/>	
VEHICLE MAINTENANCE	33
<hr/>	
Vehicle Scheduled Maintenance Chart.....	34
Maintenance Info	34
Vehicle Cleaning And Care	35
Vehicle Storage	36
Vehicle Transportation And Towing.....	38
<hr/>	
VEHICLE GENERAL SPECIFICATION.....	40
<hr/>	
MAINTENANCE LOG	41

IMPORTANT SAFETY INFORMATION

Observe these NOTICES, CAUTIONS, WARNINGS and DANGERS; be aware that servicing a vehicle requires mechanical skill and a regard for conditions that could be hazardous. Improper service or repair may damage the vehicle or render it unsafe.





Replace missing, damaged or unreadable safety decals immediately to prevent possible property damage, personal injury, or death. Purchase replacement safety decals from your dealer or distributor.

Know and understand the laws and regulations for vehicle operations in your area. For any questions on material contained in this manual, contact an authorized representative for clarification.

The components of the Save LIVES package are:

Speed management, Leadership, Infrastructure design, Vehicle safety standards, Enforcement of traffic laws and Survival after a crash.

Safe vehicles play a critical role in averting crashes and reducing the likelihood of serious injury.

IMPORTANT SAFETY INFORMATION	
	The safety alert symbol is used to alert you for possible personal injury hazards. Obey all safety regulations that follow this symbol to prevent possible injuries or death.
	A DANGER label identifies hazardous situations which may cause death or serious injuries.
	A WARNING label identifies hazardous situations which may cause death or serious injuries.
	A CAUTION label identifies hazardous situations which may cause minor or moderate injuries.
	A NOTICE label identifies hazardous situations which may cause property damages.

Read all the safety statements carefully before attempting any procedure.

OPERATING INSTRUCTIONS

- Read owner's manual and dash-mounted safety warnings prior to driving.
- Study and understand controls.
- TO OPERATE**
 - Turn wheels to desired direction and ensure path is clear.
 - Turn key to ON position.
 - While stopped, place Forward/Reverse switch in desired position: D-Drive N-Neutral R-Reverse(Buzzer will sound)
 - Press accelerator pedal to release parking brake.
 - Slowly press accelerator pedal to increase speed.
 - To stop, release accelerator pedal and press brake pedal.
- BEFORE LEAVING**
 - Press parking brake pedal until it locks and holds vehicle.
 - Place Forward/Reverse switch in NEUTRAL position.
 - Turn key OFF and remove key when not in use.
- MOTOR BRAKING**
 - Electric motor braking provides speed regulation functions.
 - Apply brakes to control vehicle speed as required.
 - System is activated only when switch is in the DRIVE position.
 - When towing this vehicle, switch must be in the NEUTRAL position.

EEV 20210401001

OPERATING INSTRUCTIONS DECAL



PINCH POINTS WARNING DECAL



HEAVY WARNING DECAL



OPERATOR WARNING DECAL



WINDSHIELD WARNING DECAL



REAR SEAT OCCUPANT WARNING DECAL

SAFETY INFORMATION

Read all the safety statements carefully before attempting any procedure.

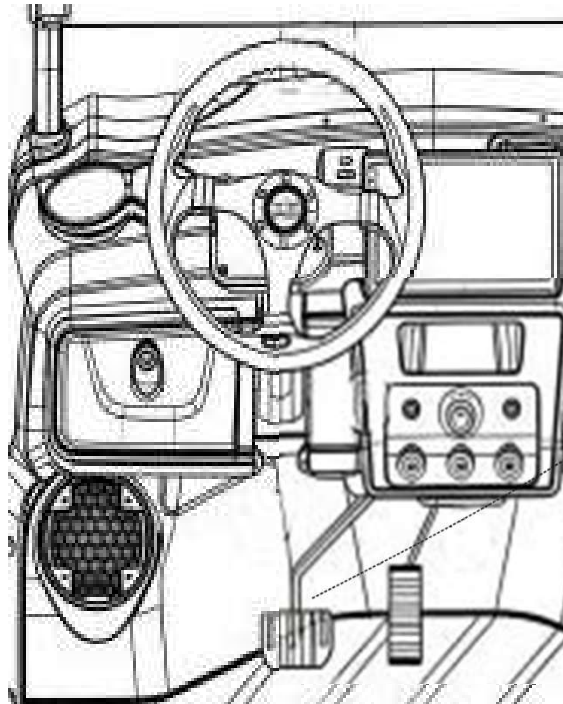

WARNING

ROLLOVER OR FALLING OFF MAY CAUSE SERIOUS INJURY OR DEATH.

- Before using vehicle, read operating instructions.
- Do not start vehicle until all occupants are seated.
- Keep entire body inside vehicle while moving.
- Drive at a low, steady speed when taking turns or operating on inclines.
- Keep vehicle as straight as possible on inclines to avoid sliding or overturning.
- Use brakes to control speed when coasting downhill.
- Never operate under the influence of alcohol or drugs.
- For use by authorized persons in designated areas only.
- Remain seated while moving.
- Operate from driver side only.
- Never operate on public roads.
- Hold on to handle rail while moving.
- One (1) person per seat maximum.
- Never stand in front of or behind vehicle.
- Do not leave children unattended on vehicle.

EEV 20220110002



WARNING

ROLLOVER OR FALLING OFF MAY CAUSE SERIOUS INJURY OR DEATH.

- Seat Belts Must Be Worn in This Vehicle at All Times.
- Hold on to the Hand Rail.
- Keep Your Arms and Legs Inside the Roly Vehicle at All Times.
- Children Are Not Allowed to Sit Alone on the Back Seats.
- One (1) Person Per Seat Maximum.
- Remain Seated While Moving.
- Do Not Start Vehicle Until All Occupants Are Seated.



EEV 20220110003

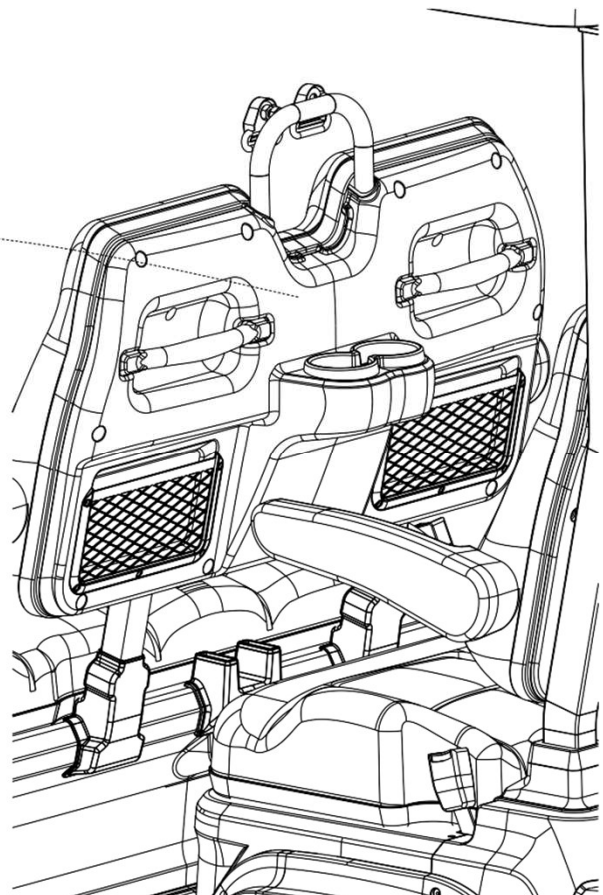

SAFETY INFORMATION

Read all the safety statements carefully before attempting any procedure.

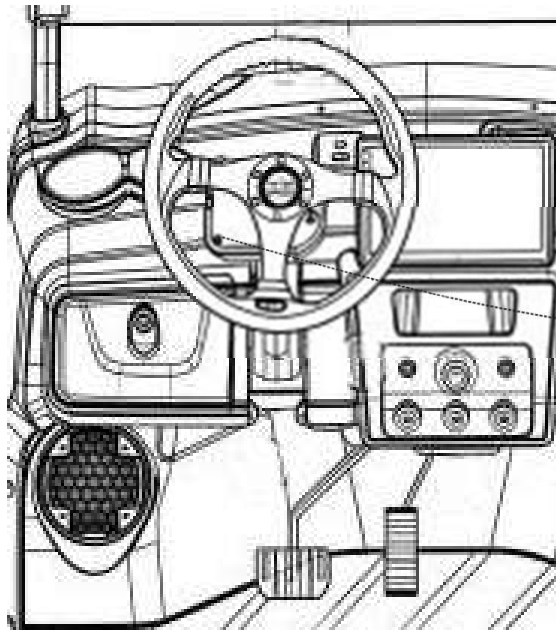

OPERATING INSTRUCTIONS

- Read owner's manual and dash-mounted safety warnings prior to driving.
- Study and understand controls.

TO OPERATE

- Turn wheels to desired direction and ensure path is clear.
- Turn key to ON position.
- While stopped, place Forward/Reverse switch in desired position: D-Drive N-Neutral R-Reverse(Buzzer will sound)
- Press accelerator pedal to release parking brake.
- Slowly press accelerator pedal to increase speed.
- To stop, release accelerator pedal and press brake pedal.

BEFORE LEAVING

- Press parking brake pedal until it locks and holds vehicle.
- Place Forward/Reverse switch in NEUTRAL position.
- Turn key OFF and remove key when not in use.

MOTOR BRAKING

- Electric motor braking provides speed regulation functions.
- Apply brakes to control vehicle speed as required.
- System is activated only when switch is in the DRIVE position.
- When towing this vehicle, switch must be in the NEUTRAL position.

(EVV 2021010101)

!WARNING FAILURE TO FOLLOW THESE INSTRUCTIONS MAY RESULT IN SEVERE PERSONAL INJURY.

- Service, removal or installation of battery pack must be performed by authorized personnel only.
- Improper handling of batteries and electrical components can result in severe personal injury.
- Do not immerse or throw the battery pack in water. Do not pressure wash the battery pack.
- Do not operate at temperatures below -4°F (-20°C)
- Do not expose to temperatures above 140°F (60°C)

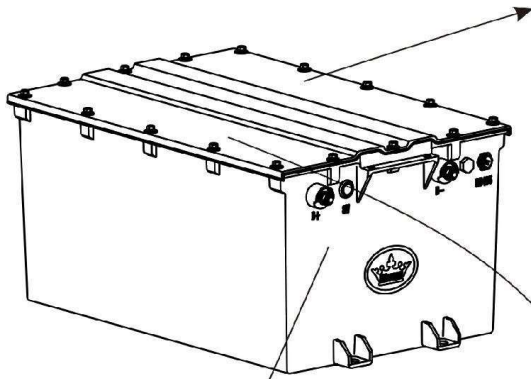

WARNING

HEAVY

LIFT WITH CARE

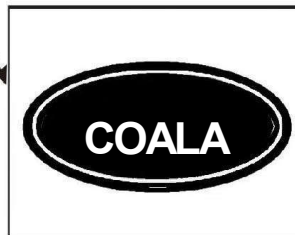

EVOLUTION ELECTRIC VEHICLES LITHIUM-ION BATTERY	
Battery Type	LiFePO4
Voltage	51.2V
Energy	5.63KWh
Capacity	150AH
Weight	143.3lb(65kg)









Read all the safety statements carefully before attempting any procedure.

BATTERY SAFETY INFORMATION

Safety and warning labels are on the lithium battery for your protection. Read and comply with the instructions on the labels for avoiding the potential risks or injuries. If any labels shown below is damaged, comes off or becomes illegible, contact your COALA dealers for replacements.



Battery Warning Decal

	While working on a li-ion battery wear protective eyeglasses and clothing
	Explosion and fire hazard. The terminals of a li-ion battery are always live, therefore do not place metallic items or tools on top of a li-ion battery. Avoid short circuits.
	Explosion and fire hazard. The terminals of a li-ion battery are always live, therefore do not place metallic items or tools on top of a li-ion battery. Avoid short circuits.
	Batteries must not be mixed with domestic or industrial waste .
	Do not open or dismantle the battery. Electrolyte is very corrosive. If the battery casing is damaged do not touch the exposed electrolyte or powder because it is corrosive.
	Do not touch any electrical components without any insulation protection.
	Batteries marked with the recycling symbol must be processed via a recognized recycling agency.
	Observe these instructions and keep them located near the battery for future. Read, understand and comply with all warning and instructions.

Read all the safety statements carefully before attempting any procedure.

LITHIUM-ION BATTERY DISPOSAL



- Lithium -ion batteries are recyclable.
- Lithium-ion batteries must be collected and recycled separately from other waste.
- Do not discard lithium-ion batteries as municipal waste.
- Speak with your dealer or distributor on returning or recycling used or damaged battery packs.
- Contact local or state environmental department for disposal information.

WARNING

Failure to operate the vehicles as instructed can cause collision, loss of control or roll over, resulting in severe injury or death. Follow all safety warnings or labels in this owner manual. All operator must read, understand and comply with these warnings and labels before operating the vehicles. Follow the safety information and operating procedures described.

- Operate your vehicle responsibly to prevent dangerous conditions for the operator, passengers and other people in the area of operation
- Operate your vehicle responsibly and keep the vehicle in safe condition of operation
- The driver must keep both hands on the steering wheel and both feet on the floor or pedals.
- Inspect the vehicle before each use to make sure it is in safe operating condition. Perform the daily inspection described in this manual.
- Always have the vehicle checked by an authorized dealer if it is involved in an accident.
- Remove the key when the vehicle is not in use to prevent accidental starting or unauthorized use.
- Drive the vehicle at appropriate speeds for the terrain and conditions. Be aware of environmental conditions that change the terrain and your ability to control the vehicle.
- Do not drive on excessively steep hills. Evaluate the terrain before descending a hill. Drive slowly and deliberately. Use the brake to limit speed and maintain control. Sudden braking or turning can cause loss of vehicle control. Drive straight up or down the hill; do not drive across the hill.
- Operate only in approved areas. Follow all applicable safety rules for the area.

VEHICLE SERIAL NUMBERS

Be familiar with vehicle features before attempting any operations.

VEHICLE SERIAL NUMBERS

All vehicles have serial numbers on the left side of the chassis frame. The first four numbers are the manufacturing year of the vehicle, the other five numbers are the vehicle's serial number given by COALA Electric Vehicles. All the vehicles are documented. After the vehicles are sold out of the factory, COALA corporation will track the vehicles by using the vehicle's serial number as identity. Serial numbers are warranty insurance from COALA corporation. Customers should be aware of the importance of vehicle serial numbers.

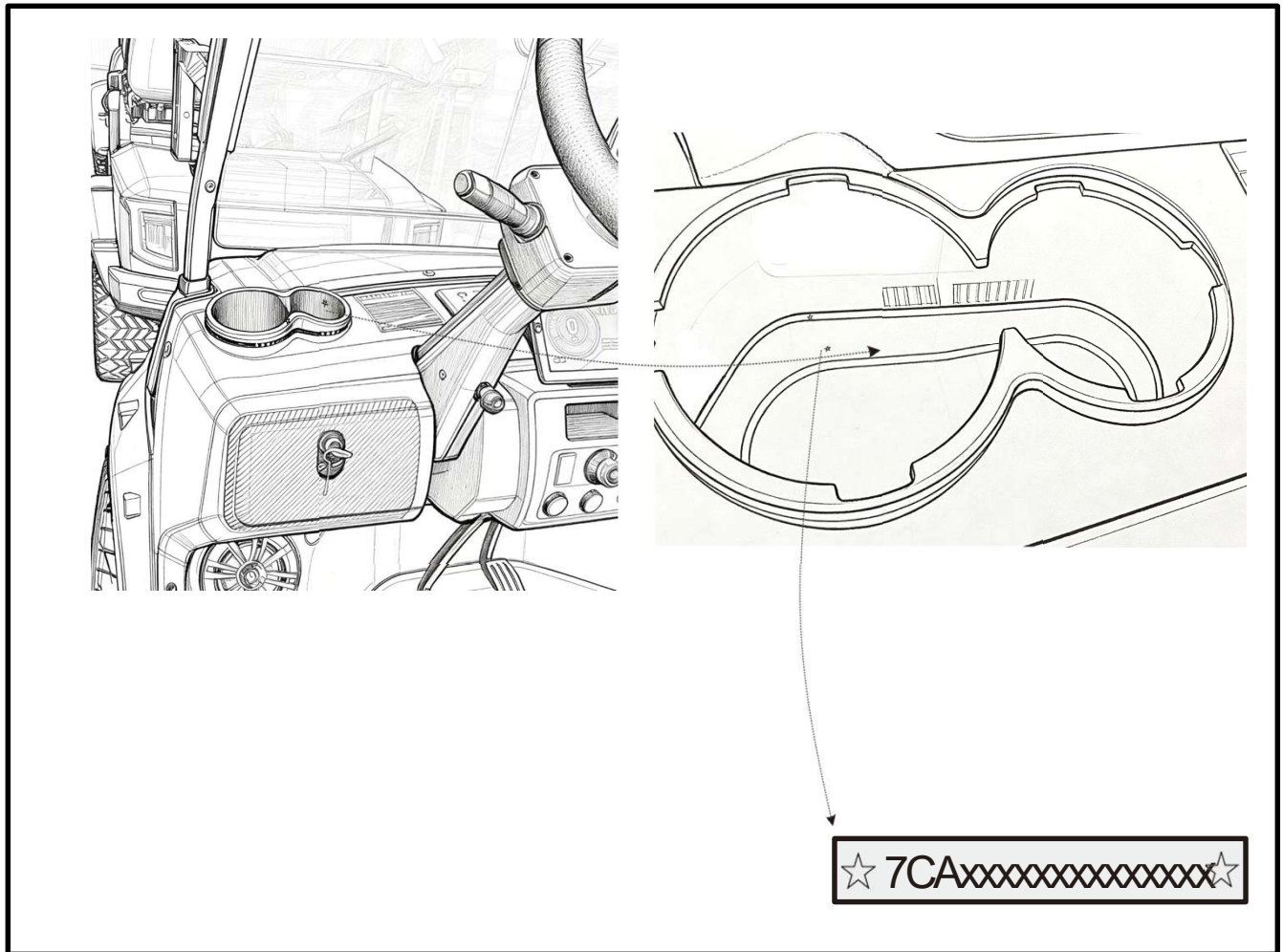

⚠ CAUTION

Design changes occur on a continuous basis. In order to get the correct components for Vehicles, the correct serial number and vehicle model must be supplied. The warranty might become invalid due to missing serial numbers .

Please contact dealer and provide the adequate purchase documents for warranty and get a new serial number plate as soon as possible.

Be familiar with vehicle features before attempting any operations.



- ① REAR VIEW MIRRORS WITH TURN SIGNAL INDICATORS
- ② FOLDABLE WINDSCREEN WITH FOLDABLE AIR VENTS
- ③ FRONT BRUSH GUARD (ONLY FOR OFFROAD MODELS)
- ④ HEADLIGHTS

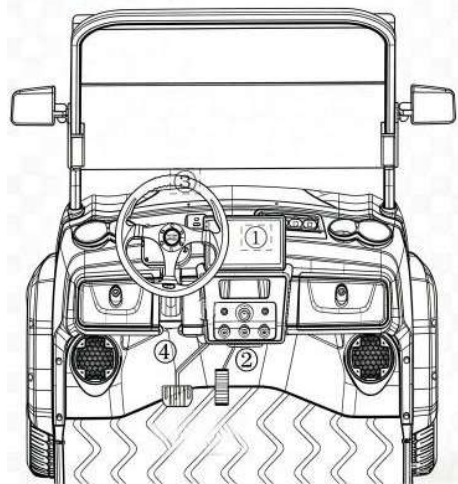

- ① 10.1 INCH MULTI-FUNCTIONAL TOUCHSCREEN
- ② MULTI-FUNCTIONAL DASHBOARD
- ③ AUTOMOTIVE STYLE STEERING WHEEL
- ④ ADJUSTABLE STEERING WHEEL IN TILTING ANGLE

VEHICLE FUTURES

Be familiar with vehicle features before attempting any operations.

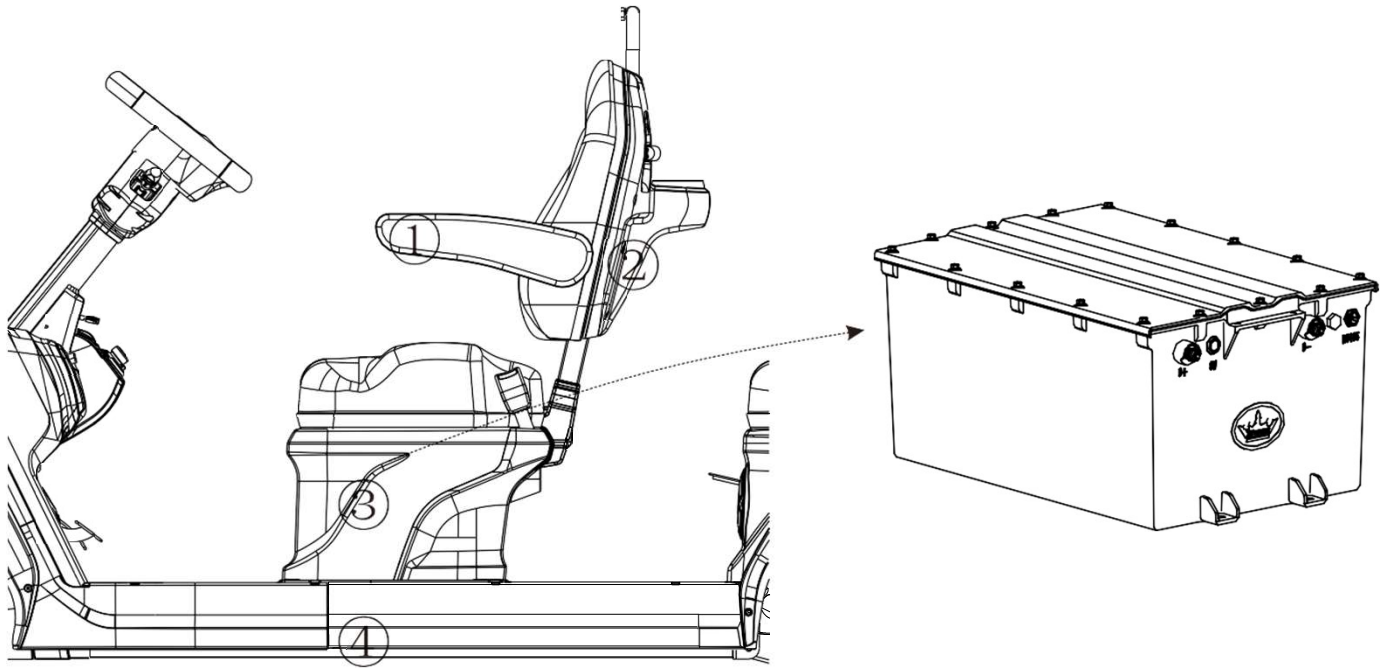

- ① LUXURY SEAT WITH FOLDABLE ARMREST
- ② REAR SEAT CUP HOLDERS, USB PORTS AND STORAGE POCKET
- ③ LITHIUM BATTERY PACK .Long Range 110AH(EXTENED RANGE 205AH OPTIONAL)
- ④ AUTOMOTIVE E-COAT CHASSIS

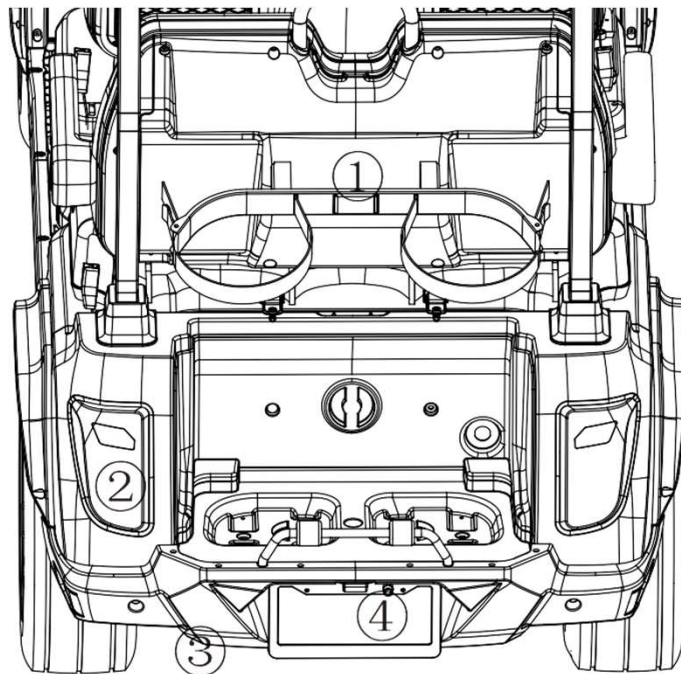

- ① GOLF BAG HOLDER(OPTIONAL)
- ② TAILLIGHTS
- ③ AUTOMOTIVE STYLE REAR BUMPER
- ④ BACKUP CAMERA

Be familiar with vehicle features before attempting any operations.

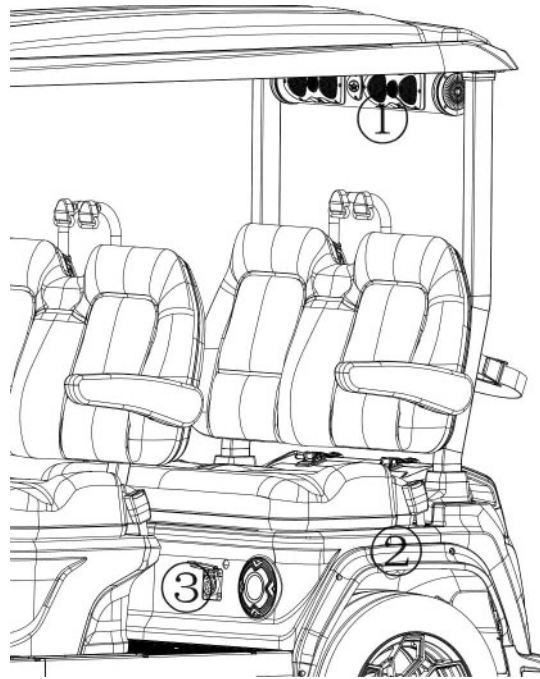

- ① TOPMOUNT SOUND BAR
- ② 3-POINT SEAT BELTS FOR EACH SEATS
- ③ 25A ON-BOARD FAST CHARGER

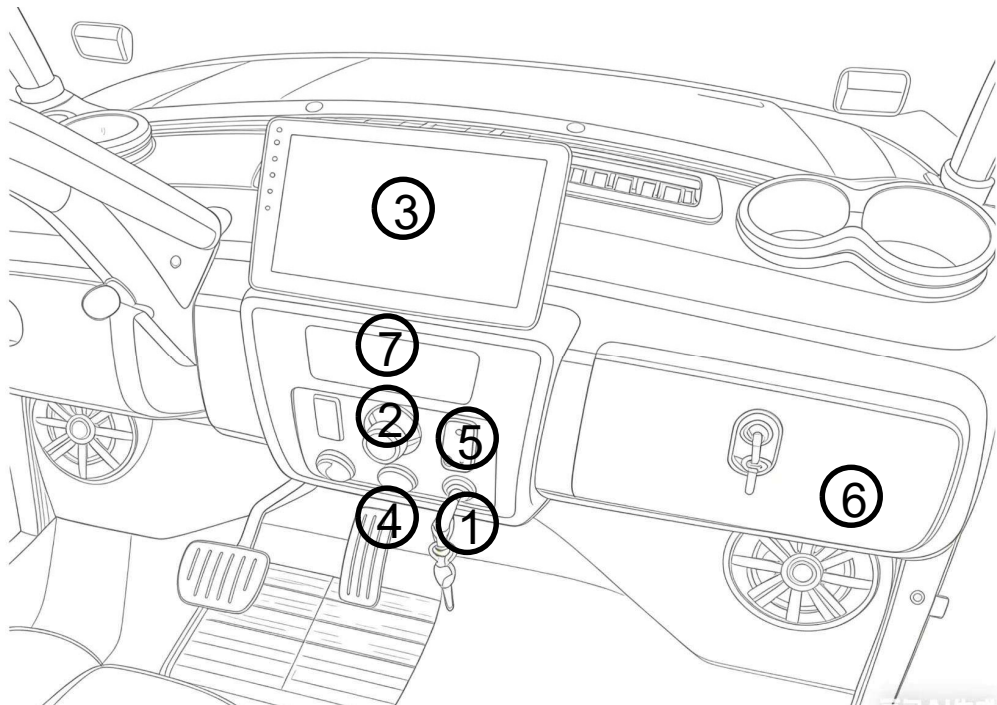

- ① POWER BUTTON
- ② DIRECTION SWITCH
- ③ 10.1 INCH TOUCHSCREEN POWER BUTTON
- ④ USB CHARGING PORTS
- ⑤ HAZARD
- ⑥ GLOVE BOX WITH LOCKS
- ⑦ STORAGE COMPARTMENT

OPERATION AND CONTROLS

Be familiar with vehicle features before attempting any operations.

DANGER

OPERATING THE VEHICLE WHILE OCCUPANTS ARE NOT FULLY SEATED CAN CAUSE SERIOUS PERSONAL INJURY OR DEATH. START THE VEHICLE ONLY WHEN ALL OCCUPANTS ARE FULLY SEATED.

FALLING OBJECTS CAN CAUSE PROPERTY DAMAGE, SERIOUS PERSONAL INJURY, OR DEATH. DO NOT OPERATE THE VEHICLE WHERE THERE IS A RISK OF FALLING OBJECTS. DO NOT LET A PASSENGER HOLD A CHILD ON THEIR LAP WHILE THE VEHICLE IS IN OPERATION. DO NOT LET PASSENGERS RIDE IN THE VEHICLE OR TRAILER BEING TOWED.

WARNING

KEEP AWAY FROM DROP-OFFS, STEEP SLOPES, AND UNSTABLE SURFACES.

SUDDEN STARTS, STOPS, AND TURNS CAN CAUSE PROPERTY DAMAGE AND SERIOUS PERSONAL INJURY. PREVENT SUDDEN STARTS, STOPS, AND TURNS. FAILURE TO CORRECTLY MAINTAIN THE VEHICLE AND MAKE NECESSARY REPAIRS CAN DECREASE VEHICLE PERFORMANCE, CAUSE A FIRE, PROPERTY DAMAGE, SERIOUS PERSONAL INJURY, OR DEATH. IF PROBLEMS ARE FOUND DURING SCHEDULED INSPECTION OR SERVICE, OPERATE THE VEHICLE ONLY WHEN REPAIRS ARE MADE.

MAKE SURE THAT ALL PASSENGERS CAN SECURE THEMSELVES IN THE VEHICLE BEFORE VEHICLE OPERATION. TO PREVENT SERIOUS PERSONAL INJURY, KEEP ENTIRE BODY IN THE VEHICLE DURING OPERATION.

THE VEHICLE IS NOT SPECIALLY EQUIPPED FOR HANDICAPPED PERSONS.

BEFORE VEHICLE OPERATION, MAKE SURE THAT ALL PERSONS COMPLY WITH THE WARNINGS AND OPERATING INSTRUCTIONS. INCORRECT OPERATION OF THE VEHICLE CAN CAUSE DECREASED VEHICLE PERFORMANCE, PROPERTY DAMAGE, SERIOUS PERSONAL INJURY, OR DEATH.

TO PREVENT FALLS FROM THE VEHICLE, PASSENGERS MUST STAY SEATED AND ALWAYS HOLD ON TO HAND HOLDS OR HANDRAILS WHEN THE VEHICLE IS IN OPERATION. THE DRIVER MUST KEEP BOTH HANDS ON THE STEERING WHEEL WHEN THE VEHICLE IS IN OPERATION.

A SHARP TURN AT HIGH SPEEDS CAN CAUSE A ROLL-OVER, FALL, PROPERTY DAMAGE, AND SERIOUS PERSONAL INJURY. OPERATE THE VEHICLE SLOWLY IN TURNS. UNINTENDED VEHICLE OPERATION CAN CAUSE SERIOUS PERSONAL INJURY OR DEATH. BEFORE LEAVING THE VEHICLE OR DURING VEHICLE MAINTENANCE, DISABLE THE VEHICLE.

THE VEHICLE IS NOT DESIGNED TO MEET CHILD SAFETY SEAT COMPATIBILITY REQUIREMENTS. CHILDREN REQUIRING A CHILD SAFETY SEAT MUST NOT RIDE ON THE VEHICLE. COMPLY WITH STATE AND LOCAL LAWS PERTAINING TO CHILD SAFETY.

CAUTION

OPERATE THE VEHICLE ONLY FROM THE DRIVERS SEAT.

OPERATE THE VEHICLE ONLY IN SPECIFIED AREAS.

ONLY AN AUTHORIZED LICENSED DRIVER CAN OPERATE THE VEHICLE.

ONLY OPERATE THE VEHICLE IN COMPLIANCE WITH LOCAL AND STATE LAWS.

USE CAUTION WHEN OPERATING THE VEHICLE IN THE PRESENCE OF HIGHER-SPEED VEHICLES, IN CONGESTED AREAS, OR ON UNIMPROVED SURFACES.

Be familiar with vehicle features before attempting any operations.

PRE-OPERATION SAFETY AND PERFORMANCE INSPECTION

Use the pre-operation checklist to inspect the operational conditions and performance of the vehicle. If bad operational conditions are found on a vehicle, stop operations. Removal from operation can prevent further damages to the vehicle or serious injuries. If the vehicle is not in an operate-able condition, inquire your dealer for maintenance or repairs.

PRE-OPERATION CHECKLIST

INSPECTION ITEMS	INSPECTION PROCEDURES
BATTERY	Before initiate using vehicle, the batteries should be fully charged, Replace the bad/broken/damaged parts during inspection.
BRAKE	Check the brake pedal , when stepped it should be flexible and feels firm . And it returns to its original position with flexibility when released
ACCELERATOR PEDAL	Check the accelerator pedal ,when stepped and released it should return to its original position with full flexibility.
TIRES	Check the tires' pressure, pressure is around 20psi. Check tires surface, remove any embedded objects you can find. Be sure no cracks or other damages to the tires ,defective tires may cause accident while driving.
STEERING	Pull the steering wheel up and down ,check the tightness of steering wheel .Rotate the steering wheel right and left. Be sure no excessive free play and rattling sound .
REVERSER WARNING BEEPER	Check the reverse beeper, when the direction selecting switch be set at "REV", it should beep soundly.
LIGHTS	Check the signal lights, the brake lights and turning lights should be in proper working condition.

Be familiar with vehicle features before attempting any operations.

PRE-OPERATION SAFETY AND PERFORMANCE INSPECTION

Before initiate using vehicle, the batteries should be fully charged.

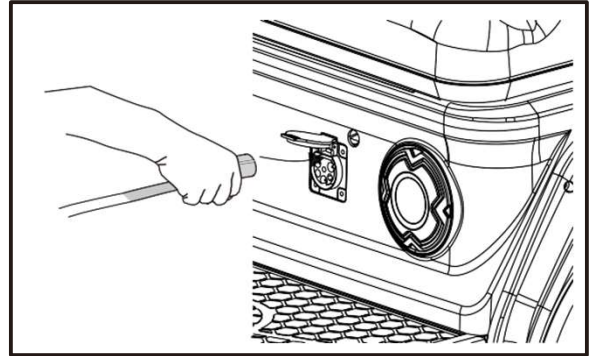

Check the accelerator pedal ,when stepped and released it should returns to its original position with full flexibility.

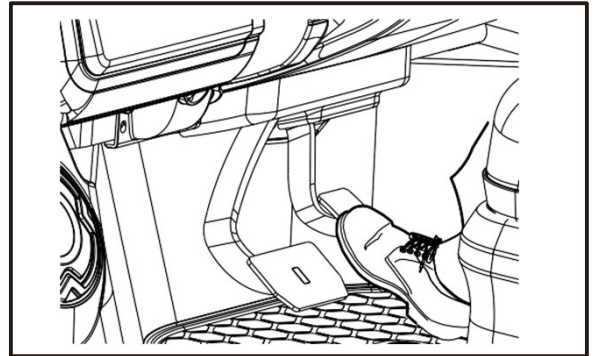

Check the brake pedal , when stepped it should be flexible and feels firm . And it returns to its original position with flexibility when released.

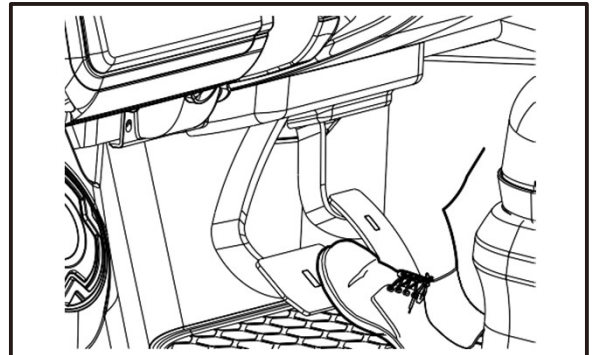

Check the tires' pressure, it should be inflated until the internal pressure is around 20PSI(138kpa)

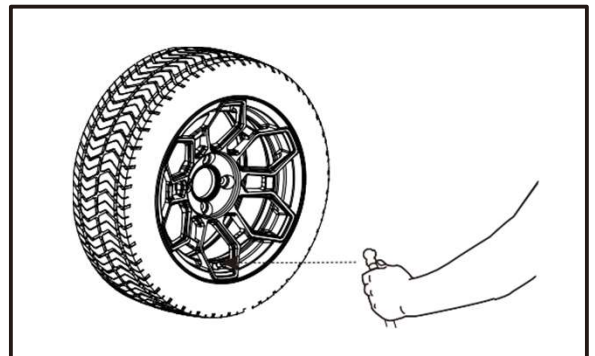

Check the signal lights , the brake lights and turning lights should be in proper working condition.

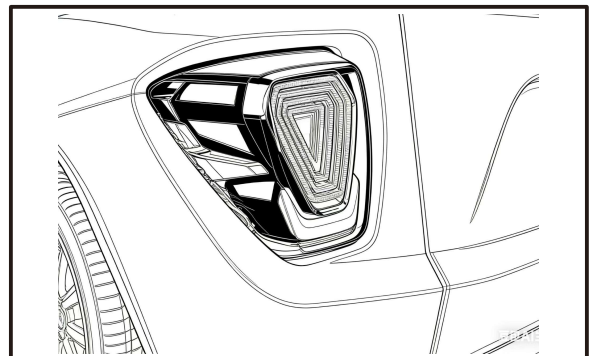

Be familiar with vehicle features before attempting any operations.

PRE-OPERATION SAFETY AND PERFORMANCE INSPECTION

Check the reverse beeper ,when the direction selecting switch be set at “REV”, it should beep soundly.

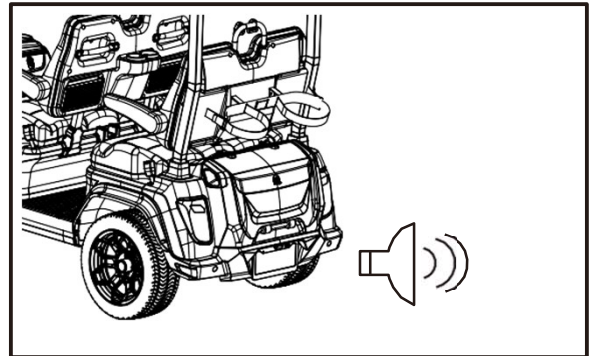

Check the tires' surface , remove any embedded objects you can find . Be sure no cracks or other damages to the tires ,defective tires may cause accident while driving.

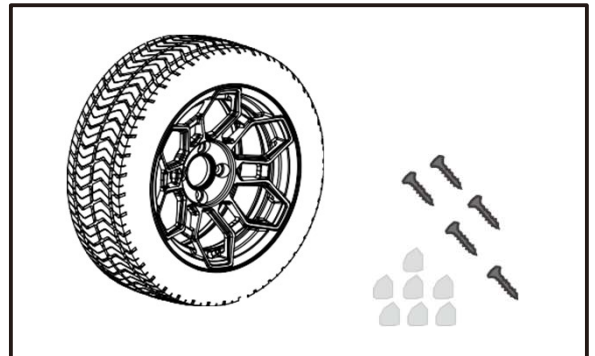

Check the lubricant capacity the rear axle contains, use a cleaned stick , stick it into the rear axle and reach the bottom , pull it out check the depth. The amount of oil should be around 0.8L.

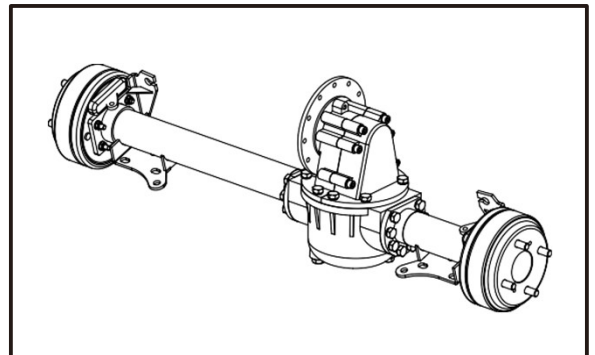

Pull the steering wheel up and down, check the tightness of steering wheel. Rotate the steering wheel right and left. Be sure no excessive free play or rattling sound.

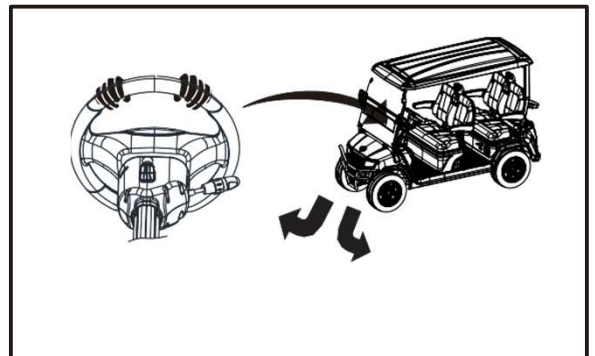

Check the tightness of the battery cables, make sure all the nuts are solidly tight. Loose nuts on the battery will cause sparks while operating.

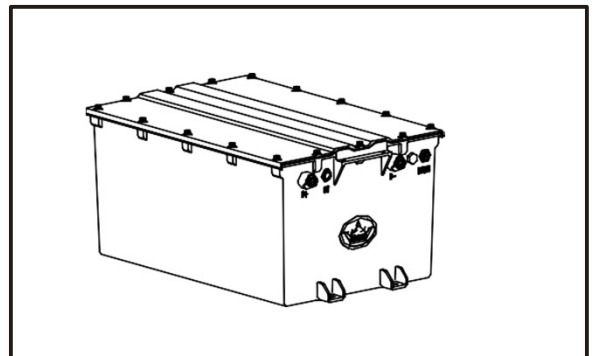

OPERATION AND CONTROLS

Be familiar with vehicle features before attempting any operations.

.START THE VEHICLE

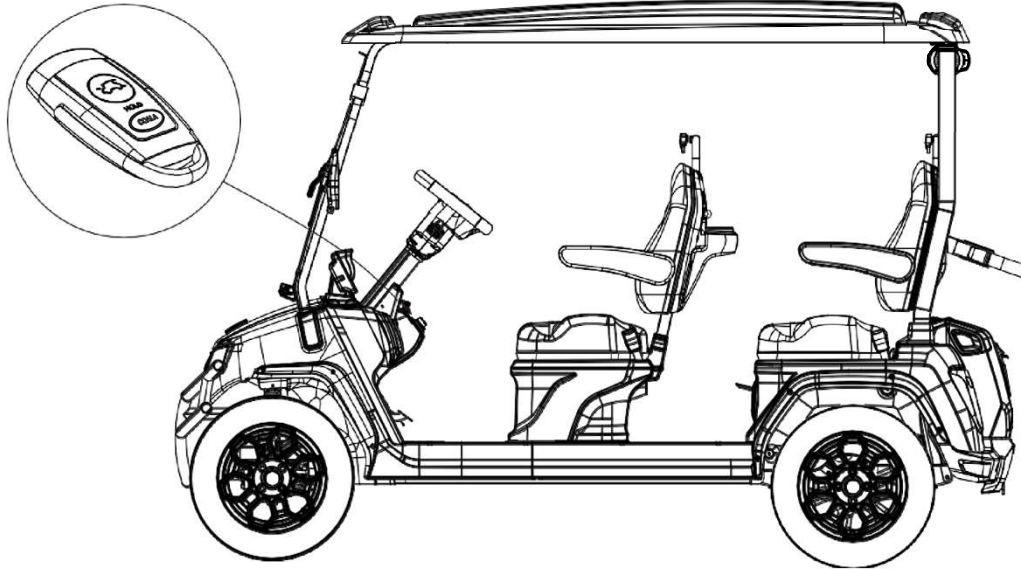

KEEP THE KEY FOB INSIDE / CLOSE TO THE VEHICLE (MAXIMUM DETECTION DISTANCE 3.3 FEET)

NOTICE

EQUIPPED WITH ONLY TWO TYPES OF KEYS. THE KEY FOB SHOWN ABOVE IS FOR STARTING AND SHUTTING DOWN THE VEHICLE ONLY, AND THE OTHER COMMON KEYS IS FOR OPENING THE GLOVE BOXES AND REAR STORAGE COMPARTMENT.

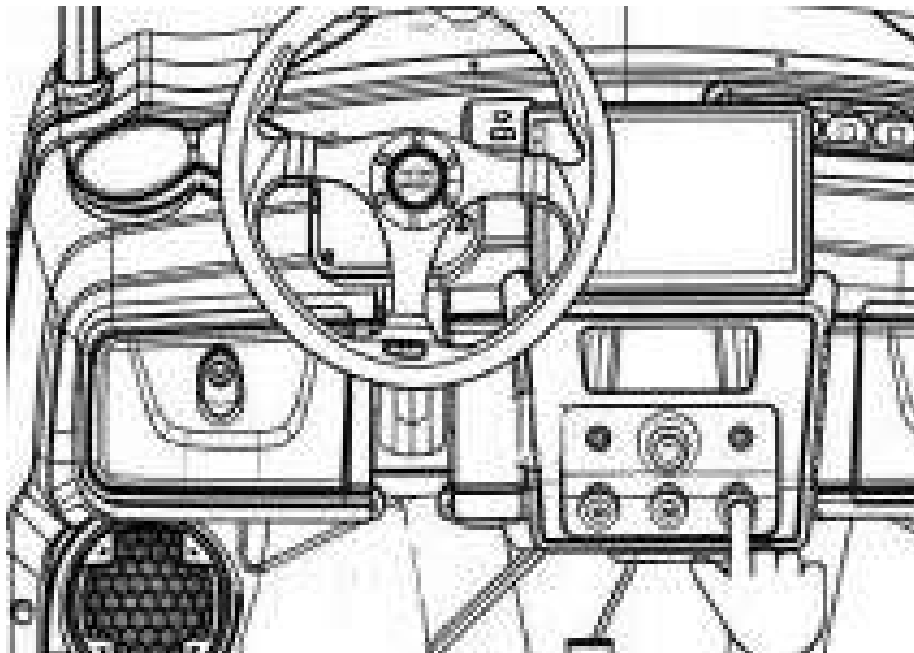

PUT THE DIRECTION SWITCH IN "N" POSITION , STEP ON THE **BRAKE PEDAL** . PRESS THE "**POWER**" BUTTON TO START THE VEHICLE .

Be familiar with vehicle features before attempting any operations.

.DRIVE AND CONTROL

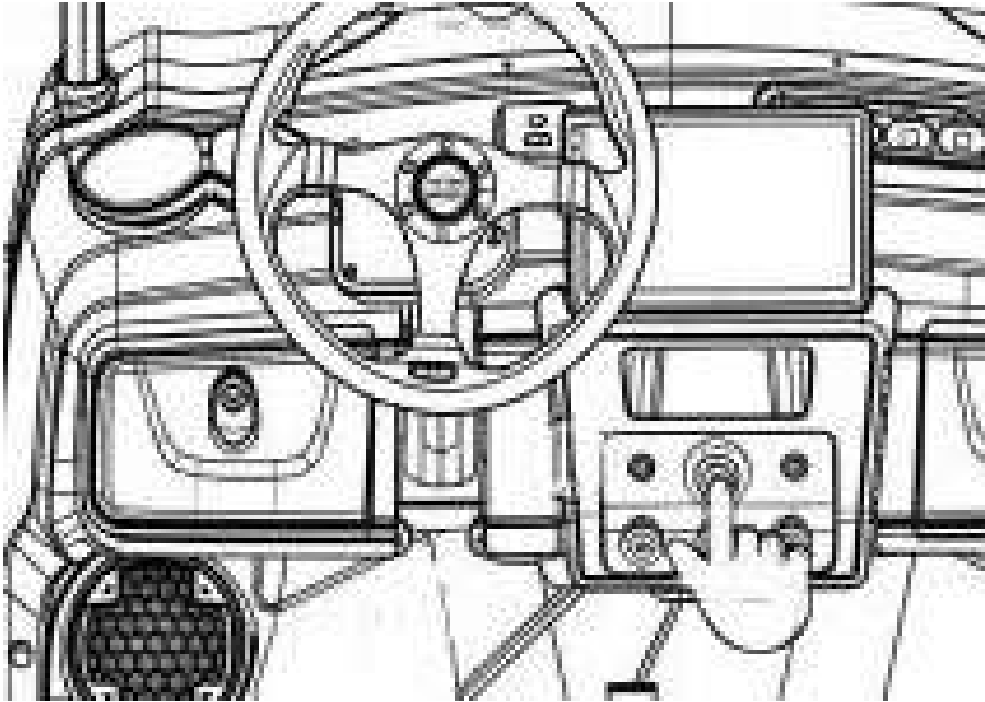

SELECT VEHICLE MANEUVERING DIRECTION.
"R" > REVERSE , "N" > NEUTRAL , "D" > DRIVE

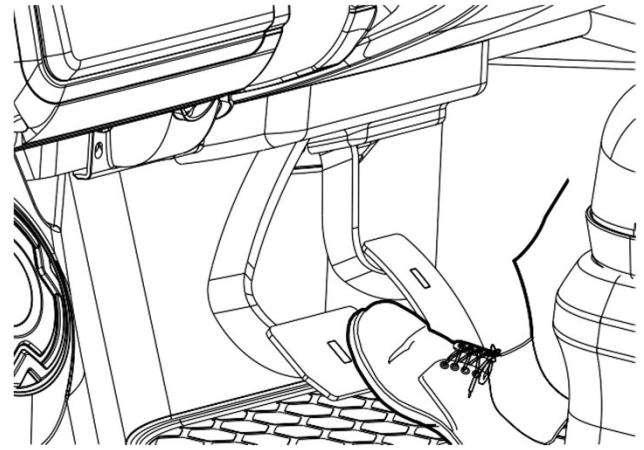
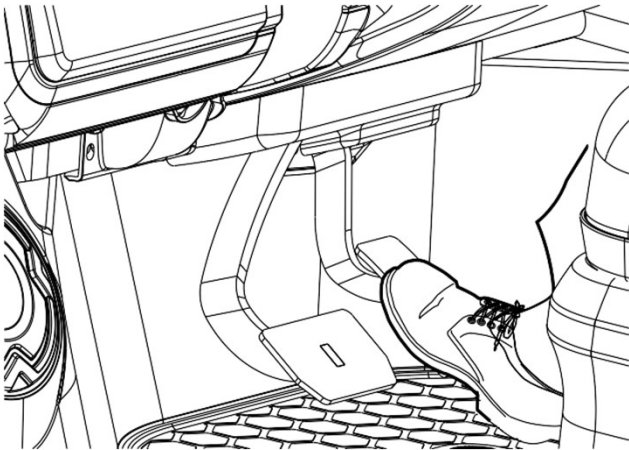

1. USE ACCELERATOR PEDAL TO ACCELERATE
2. APPLY BRAKE PEDAL TO REDUCE SPEED

OPERATION AND CONTROLS

Be familiar with vehicle features before attempting any operations.

.TURN SIGNALS

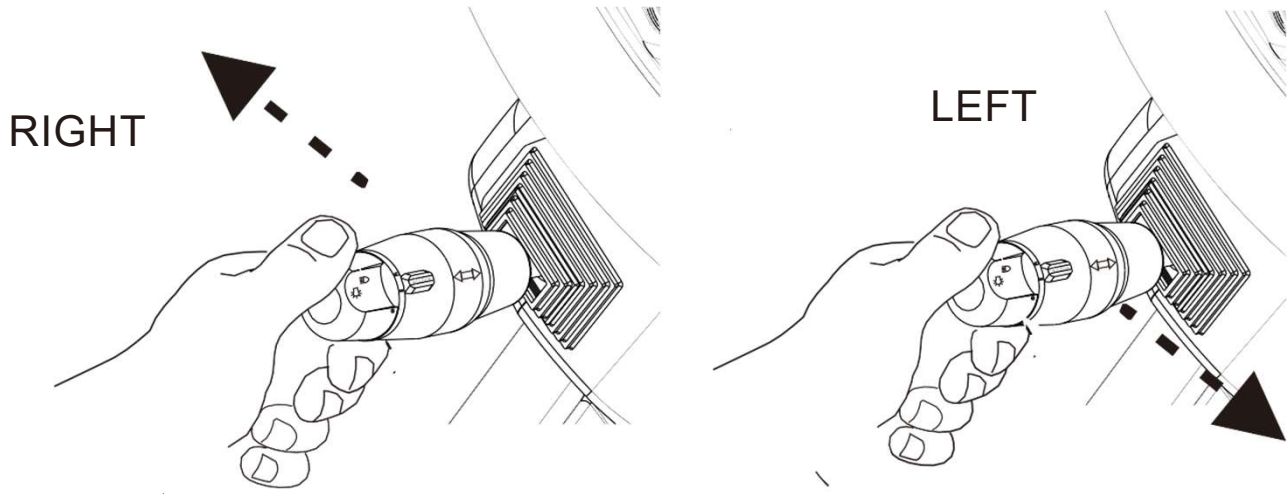

PUSH & PULL THE CONTROL STALK FORWARDS OR BACKWARDS TO ENABLE LEFT TURN SIGNALS OR RIGHT TURN SIGNALS .

.CHARGING PORTS

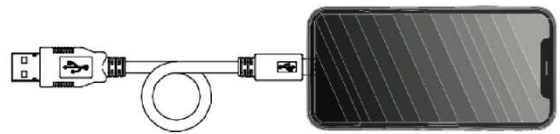
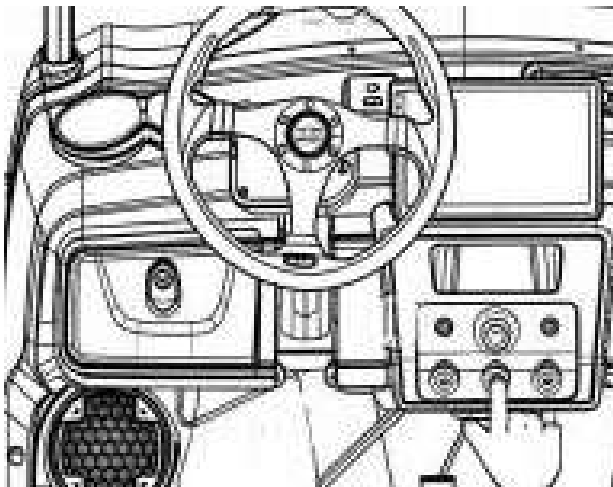

.USE THE USB CHARGING PORTS TO CHARGE YOUR PHONES

Be familiar with vehicle features before attempting any operations.

.LIGHTS CONTROL

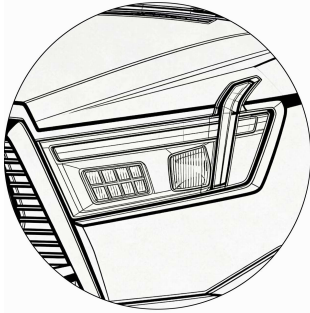

HEADLIGHT ASSEMBLY

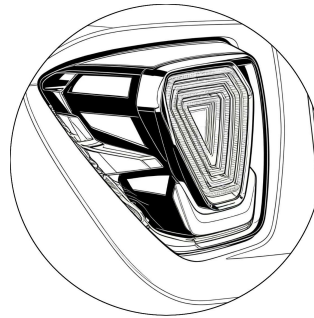

TAILLIGHT ASSEMBLY

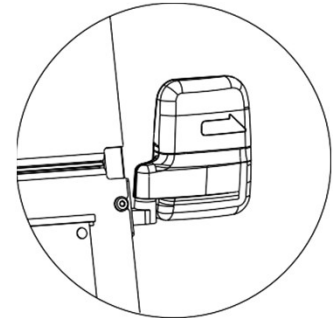

TURN SIGNAL ON REARVIEW MIRRORS

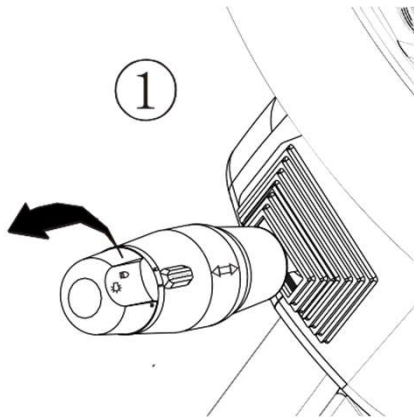

1. ROTATE THE LIGHT CONTROL KNOB TO ENABLE HEAD LIGHTS (LOW BEAM)

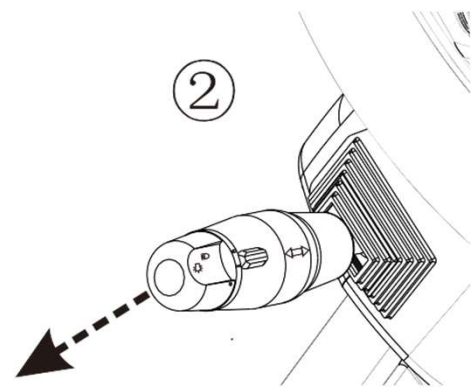

2. PULL DOWN THE CONTROL STALK TO ENABLE THE HIGH BEAM (AFTER LOW BEAM IS ENABLED)

.ADJUST THE HEIGHT OF THE STEERING COLUMN

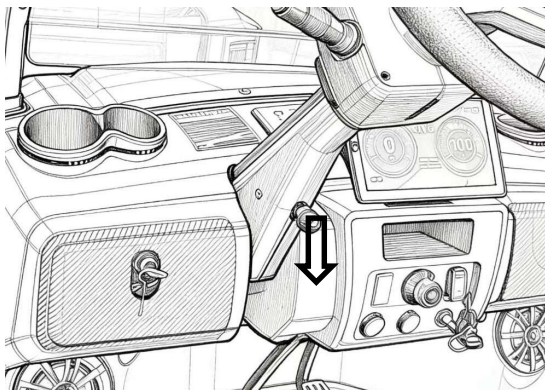

1. PRESS THE ADJUSTMENT KNOB SHOWN IN PIC 1 DOWNWARD.

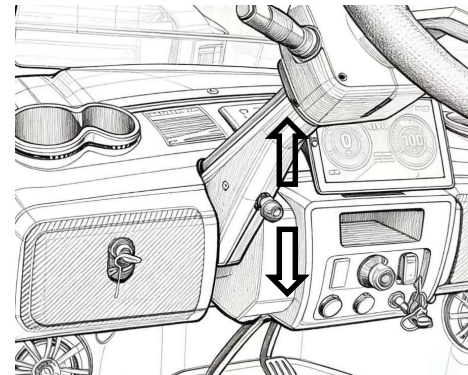

2. PUSH THE STEERING COLUMN UP/DOWN TO THE HEIGHT YOU WANT.

Be familiar with vehicle features before attempting any operations.

.ADDING BRAKE FLUID

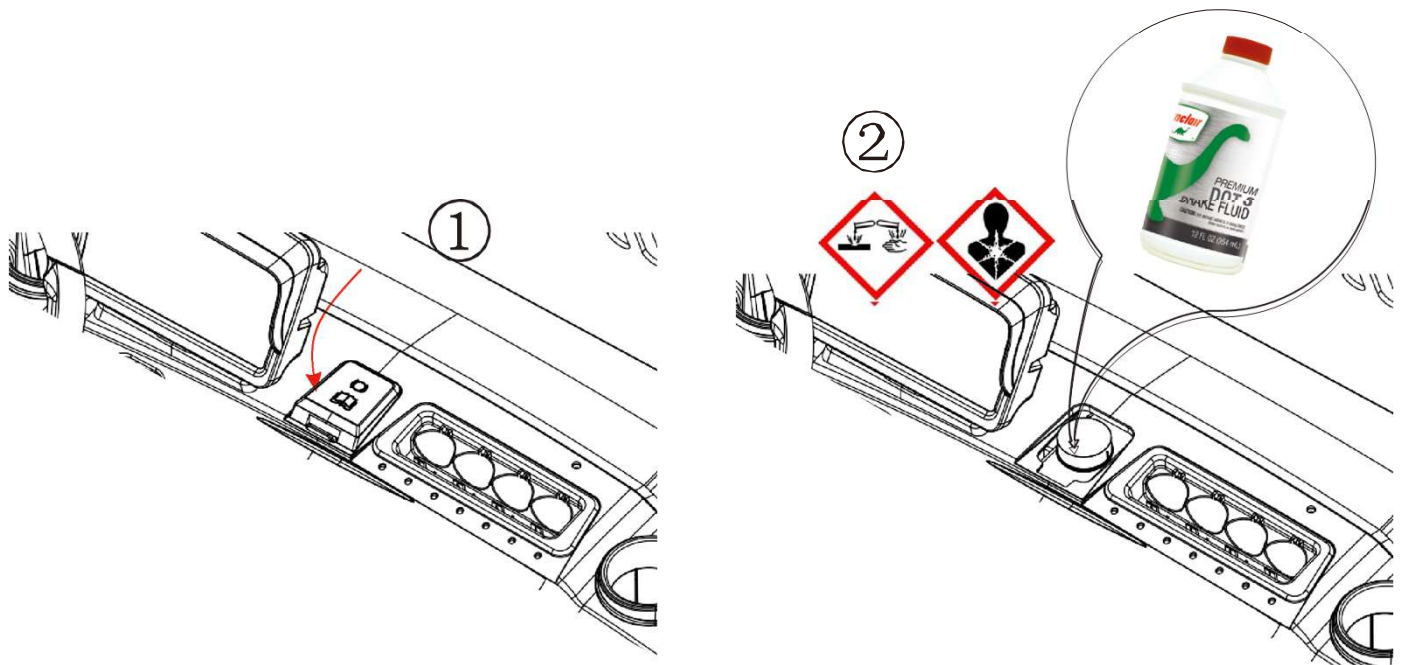

1.REMOVE THE BRAKE OIL POT COVER ON THE DASHBOARD TO GET ACCESS TO THE OIL TANK.

2.CHECK THE FLUID LEVEL ,ADD DOT 3 BRAKE FLUID TO THE TANK .

.REAR VIEW MIRROR FOLDING

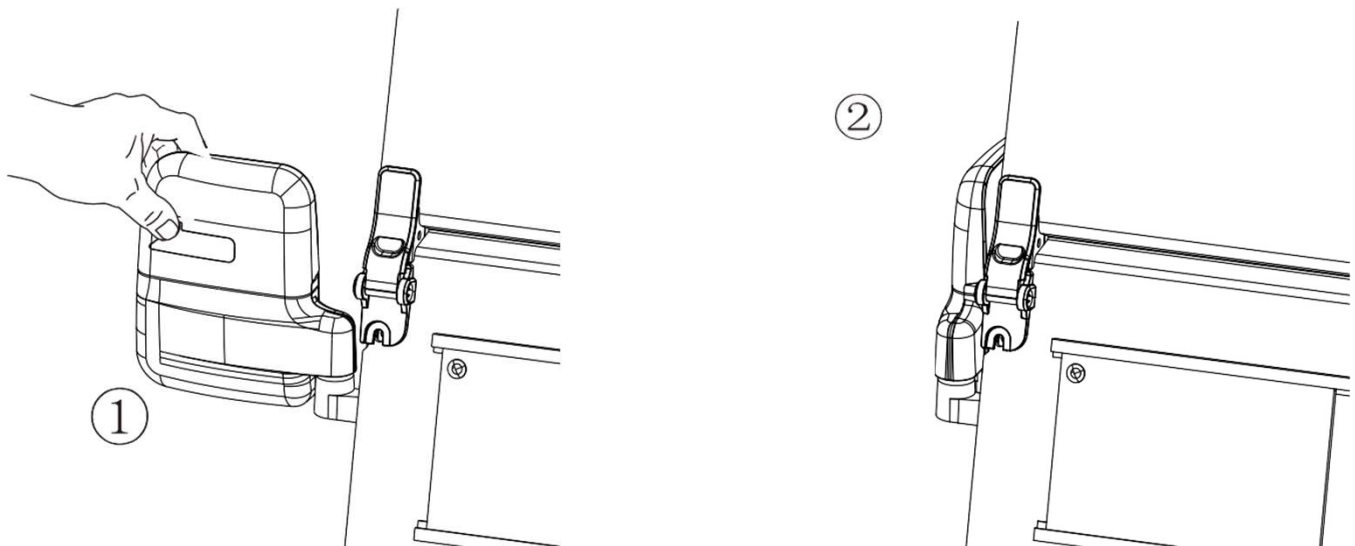

1. PUSH THE TIP OF THE REAR VIEW MIRROR INWARDS(PIC ①).
2. THE MIRROR CAN BE FOLDED INWARD 90 DEGREES(PIC ②).

Be familiar with vehicle features before attempting any operations.

.REMOVE THE STORAGE BOX

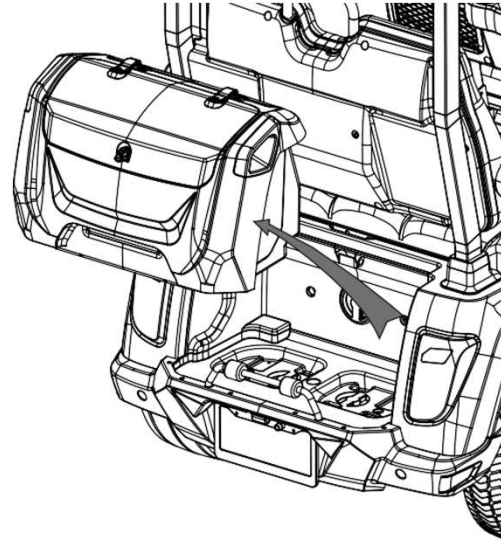
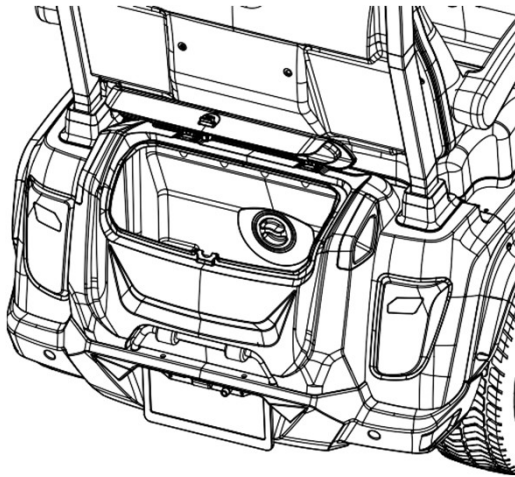

1. OPEN THE STORAGE BOX, AND EMPTY THE COMPARTMENT(PIC ①).
2. ROTATE THE THREE KNOBS INSIDE 90 DEGREES.
3. LIFT THE STORAGE BOX THEN REMOVE IT(PIC ②).

.REMOVE THE SEAT

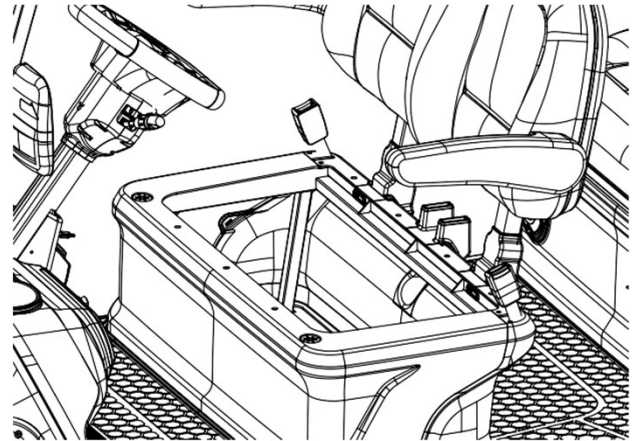
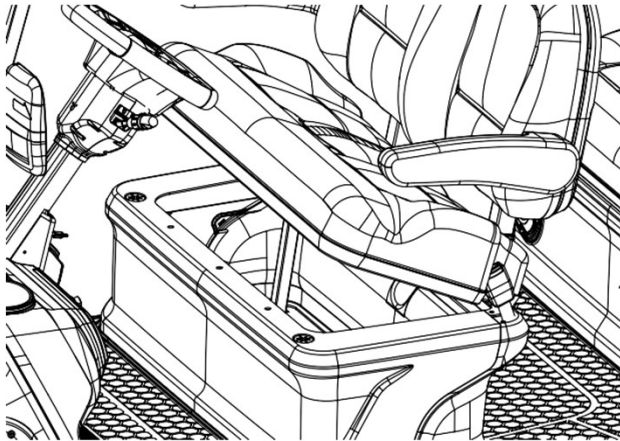

1. LIFT THE SEAT FROM THE FRONT SO THAT THE BALL AT THE BOTTOM OF THE SEAT SEPARATES FROM THE SOCKET ON THE MIDDLE BARREL.
2. REMOVE THE SEAT.

Be familiar with vehicle features before attempting any operations.

TOUCHSCREEN INTRODUCTION



BLUE TOOTH



VIDEO



MUSIC

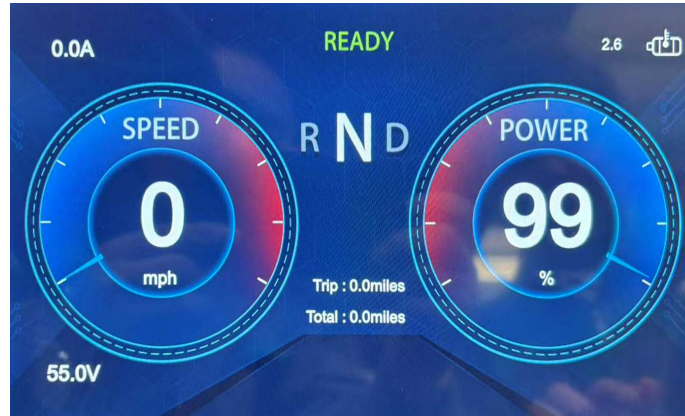

RADIO



PHOTO



SETTINGS

1. BLUE TOOTH

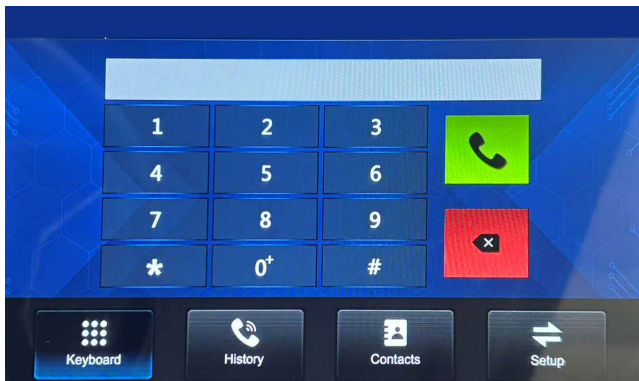

GET YOUR PHONE CONNECTED .

Step 1: Power on the vehicle .

Step 2: Enable Blue tooth function on your cell phone .

Step3 : Search for "CA-BT-XXXX" in your device list .

Step4 : Choose the device to establish the connections . now you can make phone calls or play music out of your phone .

CLICK  BUTTON TO RETURN TO THE MAIN SCREEN AND WILL NOT INTERRUPT THE CURRENT PLAYBACK.

2. RADIO



TUNE TO A RADIO STATION.

Step 1: Go to "Radio" menu .

Step 2: Hit search button to search radio stations .

Step3 : Save the stations you like .

NOTICE

YOU MAY HAVE TROUBLES WITH RADIO STATION TUNING DUE TO LOCAL RADIO SERVICE ISSUES.

Be familiar with vehicle features before attempting any operations.

3.VIDEO, PHOTO AND MUSIC

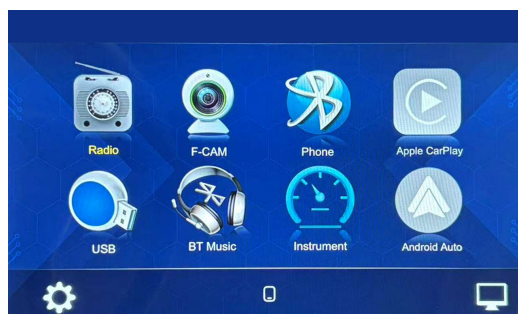

①

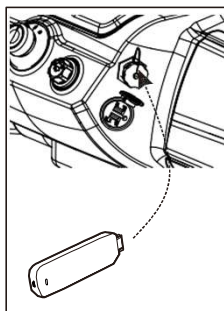

②

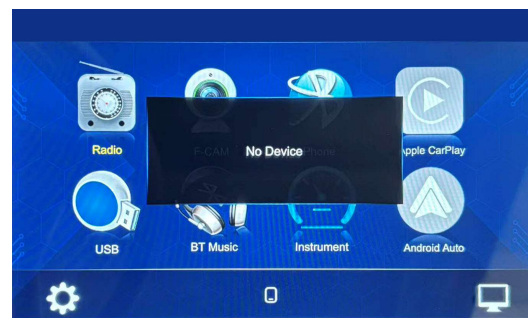

③

PLAY YOUR MEDIA (VIDEO&MUSIC FILES).

Step 1: Copy the video & music files into a USB flash drive.

Step 2: Plug it to the touchscreen USB plug(PIC 2) .

Step3 : Click on VIDEO OR MUSIC icon to get access to the file you want to play .

Step4 : If there is no flash drive plugged in , when you click on the VIDEO OR MUSIC icons it will have "No Disk " notice (PIC 3) .

4.SET

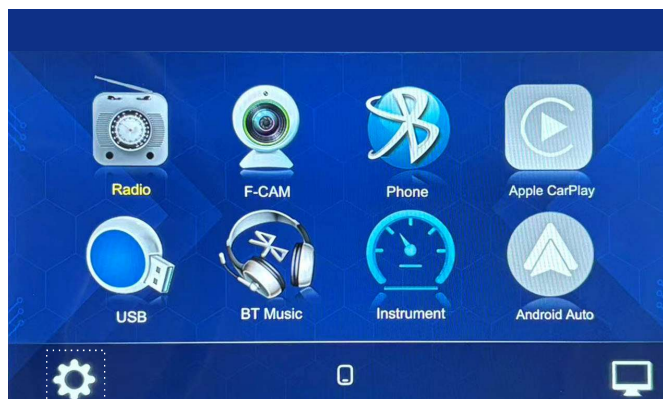

SET UP YOUR TOUCHSCREEN.

Step 1: Go to "Set" menu.

Step 2: Select the setting items you intend to change

Step3 : Change item to the value you prefer. The value will be active right away after you change it .

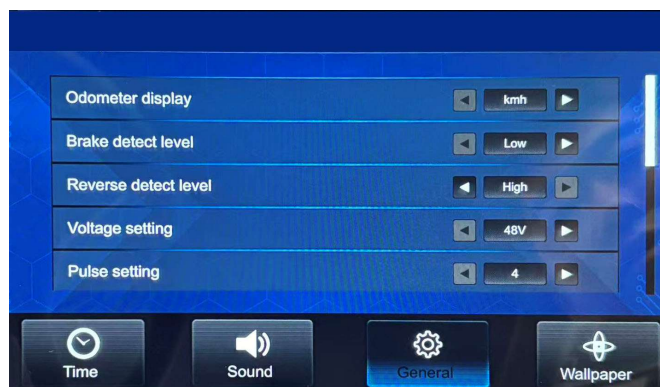

CHANGE ROUTE UNIT BETWEEN MILES AND KM

Step 1: Go to "Set" menu.

Step 2: Find Unit setting under "BASIC".

Step3 : Click  button to change the unit.

Be familiar with vehicle features before attempting any operations.

TOUCHSCREEN SYSTEM VERSION

Step 1: Go to "Set" menu .

Step 2: Find "ABOUT" menu

Step3 : Check out the system version info.

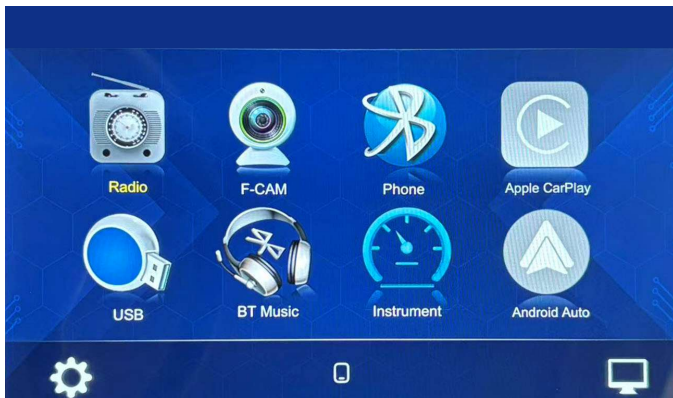

NOTICE

FOR IMPROVING THE CUSTOMER EXPERIENCE WITH THE TOUCHSCREEN NEWEST FIRMWARE MAY NEED TO BE UPDATED TIME TO TIME .

CHANGE THE LANGUAGE.

Step 1: Go to "Set" menu.

Step 2: Find Language setting under "BASIC".

Step3 : Click  button to change the language.

NOTICE

SOME LANGUAGES MAY NOT BE AVAILABLE IN THIS TOUCHSCREEN DUE TO VERSION LIMITATION .



CHANGE LOCATION SETTINGS.

Step 1: Go to "Set" menu.

Step 2: Find Local setting under "BASIC"

Step3 : Click  button to change the country region.

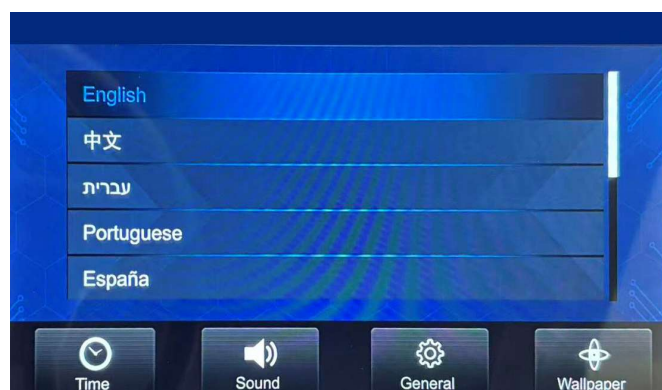

Be familiar with vehicle features before attempting any operations.

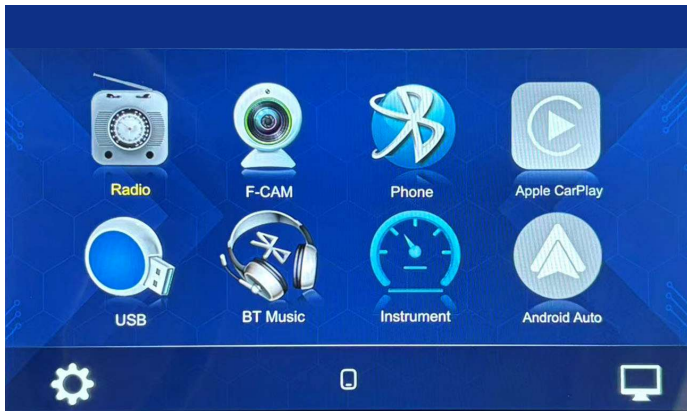

CHANGE AUTO PLAY MODE.

Step 1: Go to "Set" menu .

Step 2: Find Auto Play setting under "BASIC".

Step3 : Click  button to change the play mode.

MENU LIST>

"NO" -Nothing is being set up

"Music First" -system will play music as priority

"Movie First"-system will play movie as priority

5.OTHERS

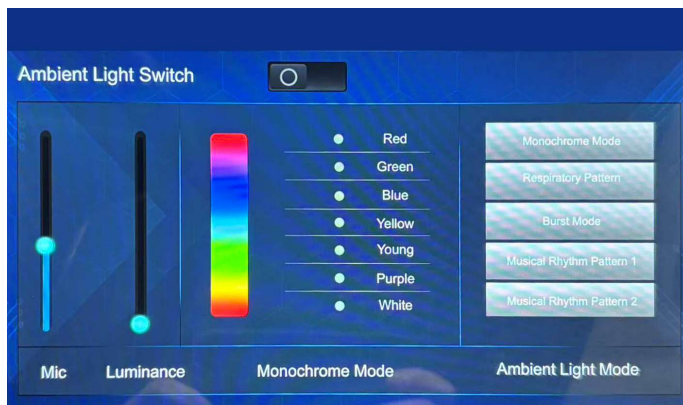



CHANGE TOUCHSCREEN BRIGHTNESS.

Step 1: Go to "Set" menu .

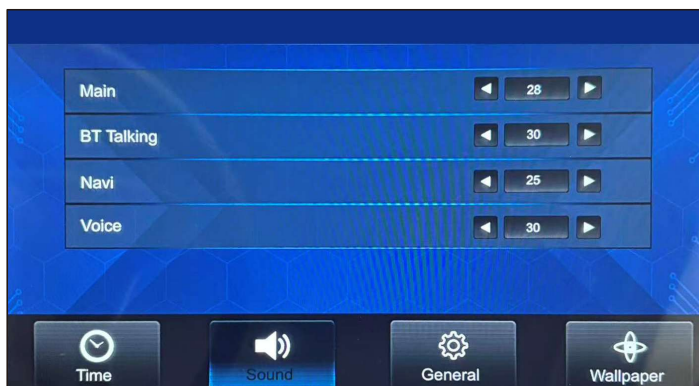
Step 2: Click  button to change the brightness.



CHANGE VOLUME.

Step 1: Click  or  button on the left side of the touchscreen to change the volume.

Be familiar with vehicle features before attempting any operations.

6.TOPMOUNT SOUND BAR

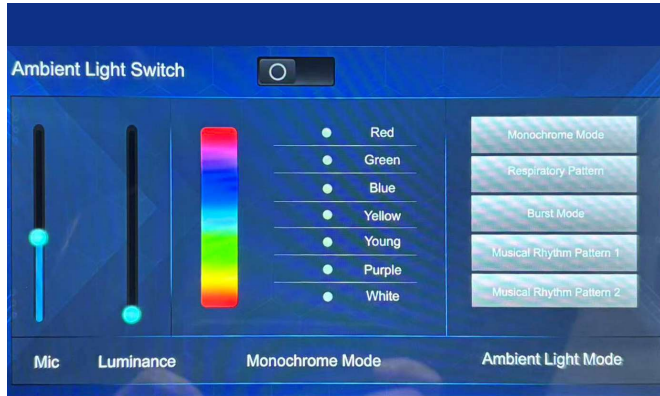

CHANGE MODE.

Step 1: Click on the location shown to switch the light strip display mode.

OPTIONAL ACCESSORIES

.GOLF BAG HOLDER

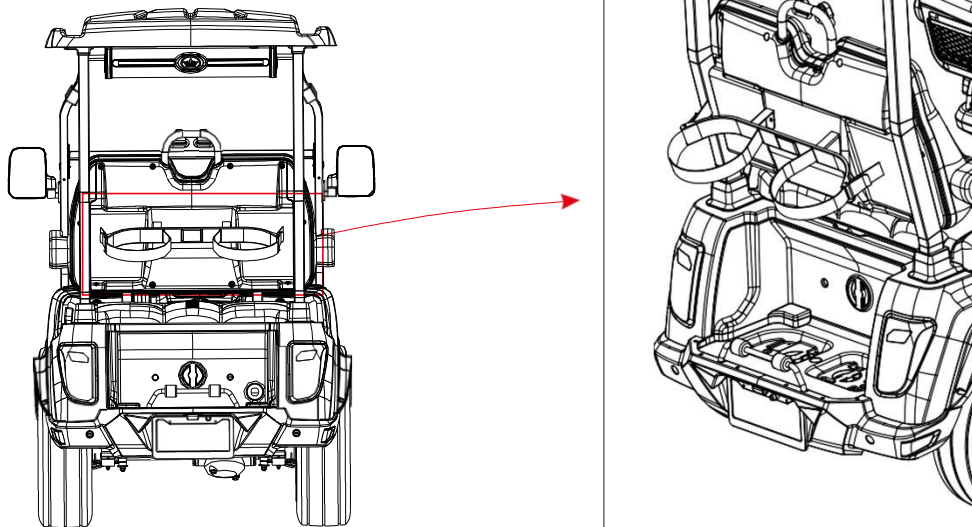

1. LOOSEN THE CLAPS ON BOTH SIDE OF THE GOLF BAG HOLDER.
- 2.ADJUST THE GOLF BAG SUPPORT BELT TO THE SUITABLE LENGTH, AND FASTEN THE SNAP.

Be familiar with vehicle features before attempting any operations.

.LITHIUM BATTERY

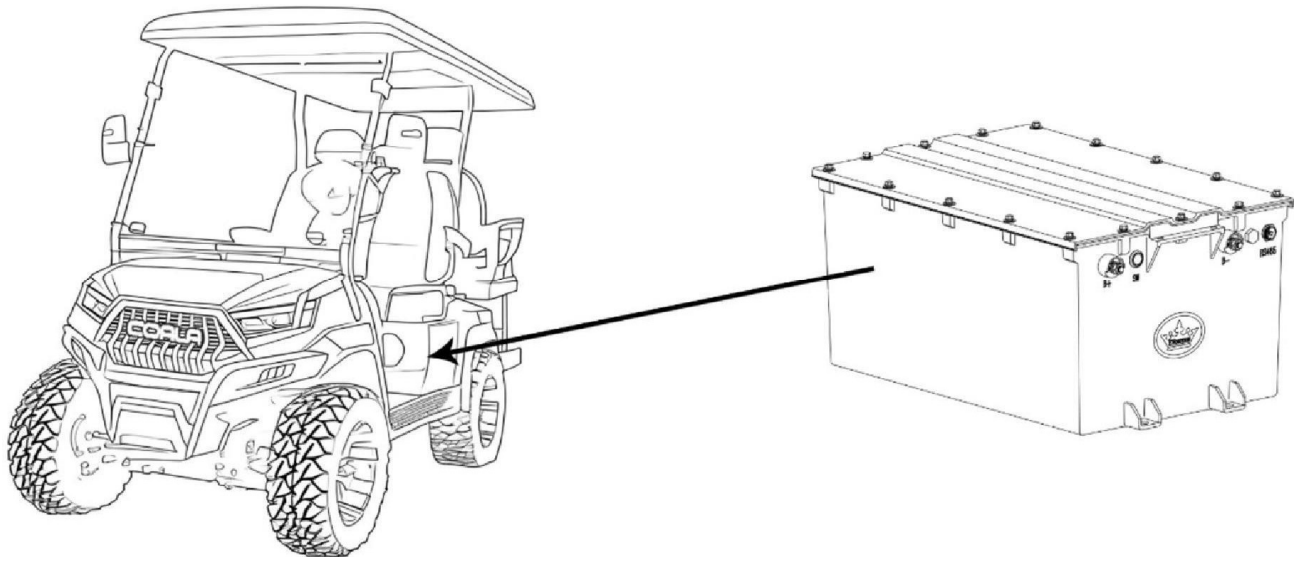

The lithium iron phosphate battery (LiFePO₄ or LFP) is the safest of the mainstream lithium battery types. A single LFP cell has a nominal voltage of 3.2V. A 48V LFP battery consists of 16 cells connected in series.

LFP is the chemistry of choice for very demanding applications. Some of its features are:

- Rugged-It can operate in deficit mode during long periods of time.
- High round trip efficiency.
- High energy density -More capacity with less weight and volume.
- High charge and discharge currents -Fast charge and discharges are possible.
- Flexible charge voltages.

The battery is equipped with Bluetooth and uses this to communicate with the BMS app. The BMS app is used for reading out battery information, receiving alarms, etc.

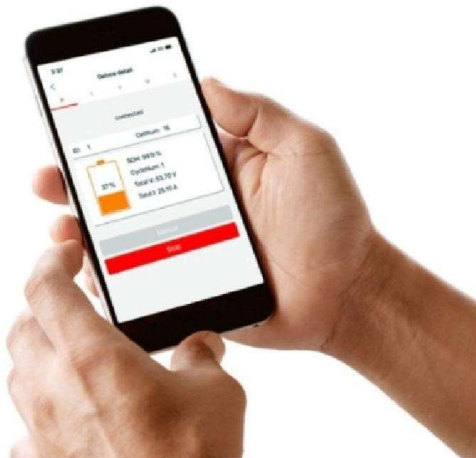

BATTERY CHARGER

Be familiar with vehicle features before attempting any operations.

.BATTERY CHARGER

 **WARNING**

INCORRECT CONNECTION OF THE AC CORD CAN CAUSE A FIRE OR AN ELECTRICAL SHOCK. DO NOT USE AN ADAPTER TO CONNECT THE AC CORD INTO A TWO-PRONG POWER SOURCE. CONNECT THE AC CORD TO AN APPROVED POWER SOURCE. CONNECTION OF THE AC CORD TO AN INCORRECT RECEPTACLE CAN CAUSE A FIRE, ELECTRICAL SHOCK, PROPERTY DAMAGE, SERIOUS PERSONAL INJURY, OR DEATH. CONNECT THE AC CORD TO AN APPROVED POWER SOURCE AND RECEPTACLE. DO NOT LET THE BATTERY CHARGER BECOME WET. KEEP THE BATTERY CHARGER DRY.

CHARGER SPECIFICATION

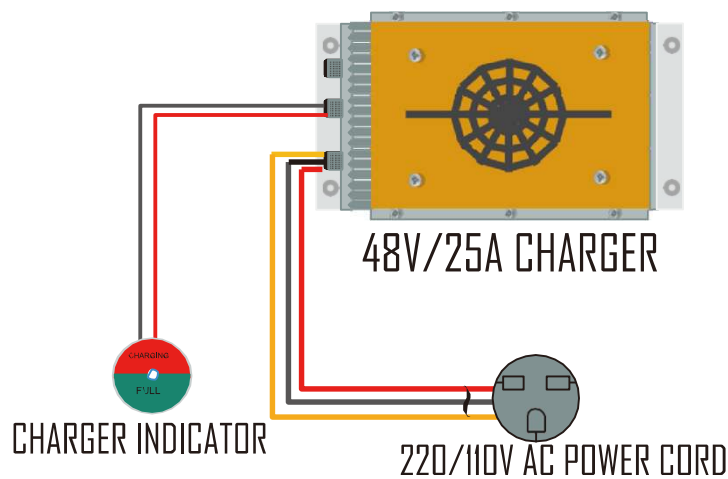

Battery pack rated voltage	48V
Maximum charger output	68V
AC input voltage range	85-270VAC, 45-65Hz
AC input current value	11.5A@120VAC, 6.1A@220VAC
Power factor	0.99
Charger efficiency	95%
Noise	45dB
IP Class	IP67
Weight	9.3lb (4.2kg)
Operating temperature	-86
Storage temperature	

Be familiar with vehicle features before attempting any operations.

HOW TO USE CHARGER

WARNING

TO DECREASE THE POSSIBILITY OF ELECTRICAL SHOCK OR ELECTROCUTION, MAKE SURE THE CHARGER PLUG IS NOT DAMAGED. THE POWER AC CORD HAS A PLUG WITH GROUND POST. DO NOT MOVE, CUT OR BEND THE GROUND POST.

1. Inspect the charger cord to check if there is broken or damaged on the power AC cord and cable. Replace the broken AC power cord.
2. Plug the AC charge handle into the vehicle receptacle completely.
3. Plug the Power AC cord into the ground power completely.
4. The charger will automatically start in several seconds after plugging in the AC power cord.
5. The charger will automatically stop when the batteries are fully charged.
- 6- Remove the AC charge cord before operating the vehicle.

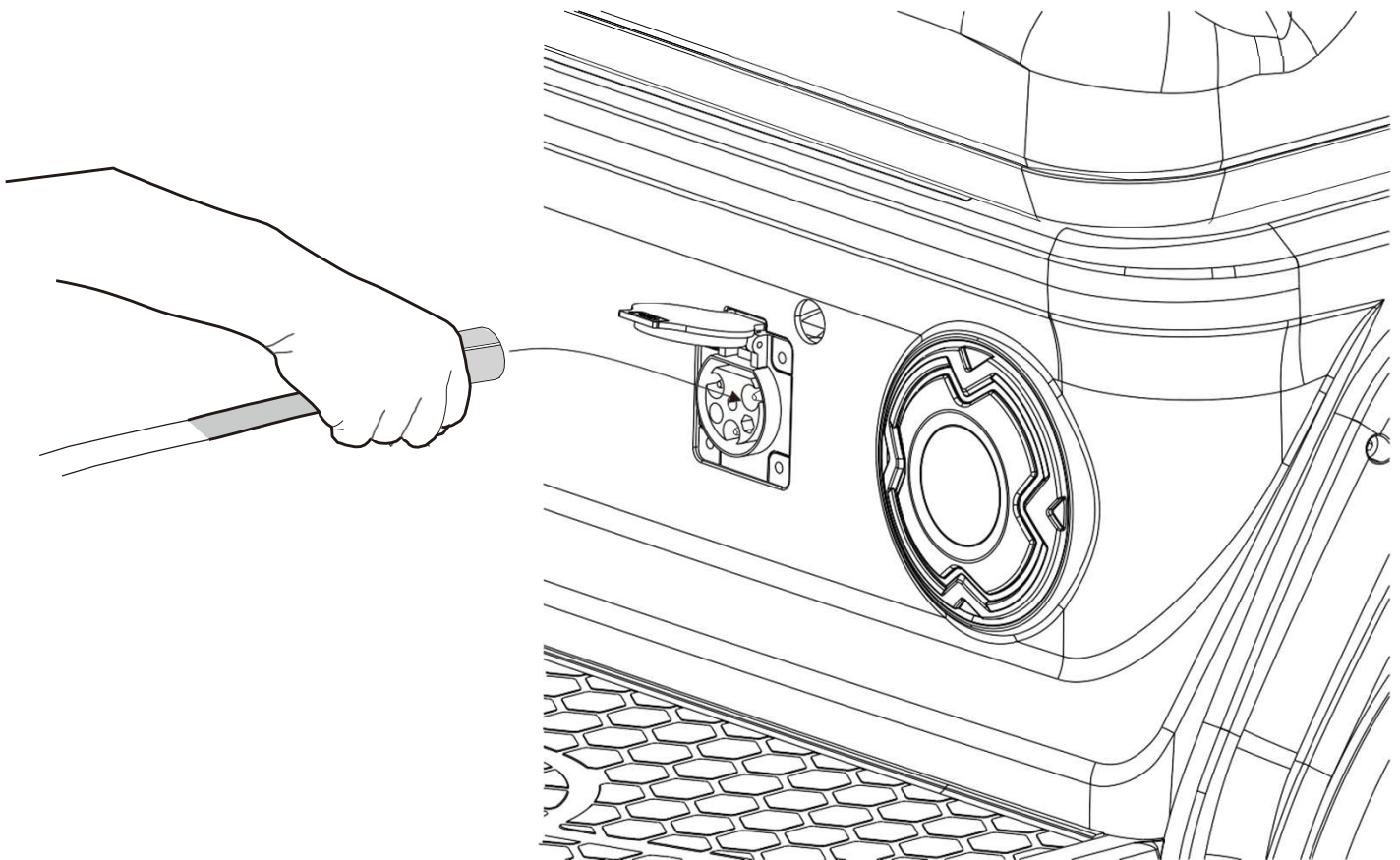

WHEELS & TIRES

Be familiar with vehicle features before attempting any operations.

WHEELS & TIRES

⚠ WARNING

DO NOT OVER INFLATE THE TIRES. EXCESS PRESSURE CAN CAUSE THE TIRE TO EXPLODE.

TO DECREASE THE RISK OF TIRE EXPLOSION, ADD SMALL AMOUNTS OF AIR TO THE TIRE AT INTERVALS TO SEAT THE TIRE BEADS. OVER INFLATION OF SMALL TIRES CAN OCCUR IN A FEW SECONDS.

PROTECT FACE AND EYES WHEN REMOVING THE TIRE VALVE CORE.

USE ONLY SOCKETS MADE FOR IMPACT WRENCHES TO DECREASE THE RISK OF INJURY CAUSED BY A BROKEN SOCKET.

DO NOT USE TIRES THAT HAVE INFLATION PRESSURE LESS THAN THE TIRE PRESSURE RECOMMENDED.

Always follow the cross-sequence pattern when you install the lug nuts to make sure the wheel is evenly seated against the hub.

NOTICE

Tools list

Lug Wrench, M19.....	1
Impact Wrench.....	1
Impact Socket, M19.....	1
Torque Wrench.....	1

The general recommended tire inflation pressure is 20 psi, but the tire inflation pressure can be changed according to the specific terrain condition.

All four tires must have the same pressure for the best control qualities. Always put the valve stem cap back after checking or inflate the tires.

Use a tire plug to repair small holes in the thread part of the tires. For large holes or cuts, replace the whole tire.

>With the valve stem to the outside of wheel, install the wheel&tire on the hub with lug nuts.

>Tighten the lug nuts with your fingers in the cross sequence pattern as shown.

>Tighten the lug nuts to 50-85 ft.lbs torque.

>Continue to follow the cross sequence pattern until the correct torque is reached.

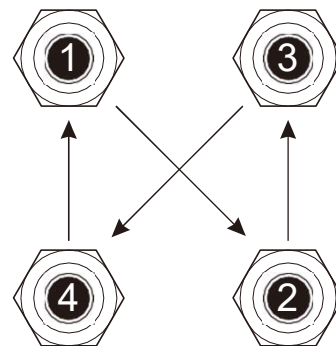
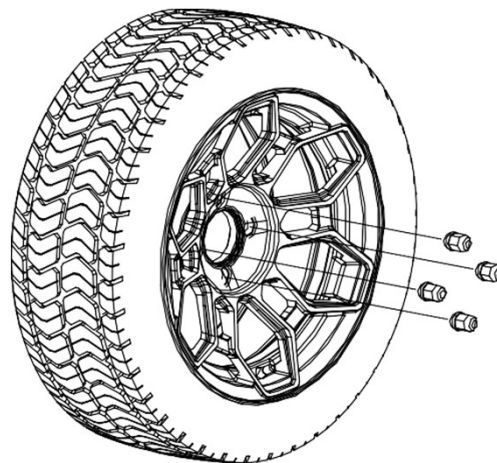

Cross Sequence

Be familiar with vehicle features before attempting any operations.

CHARGER MAINTENANCE



WARNING

IF THE PLUG PINS ARE BENT, SPEAK WITH YOUR LOCAL DEALER OR DISTRIBUTOR FOR REPLACING. DO NOT TRY TO REPAIR THE AC CORD PLUG OR PINS.

ELECTRICAL CORDS

Examine electrical cords for wear and damage before use. Immediately replace electrical cords for:

- Cracks
- Cuts
- Frayed wiring
- Insulation damage
- Loose connections
- Splices

ELECTRICAL PLUGS AND RECEPTACLES

Examine electrical plugs for wear and damage before use. Immediately replace electrical plugs for:

- Bent pins
- Corrosion
- Cracks
- Loose connections
- Missing pins

CLEAN THE ELECTRICAL PLUGS AND RECEPTACLES



1. Disconnect the AC cord from the power source.
2. Disconnect the AC cord from the battery charger.
3. Disconnect the DC cord from the vehicle charger receptacle.
4. Apply electrical contact cleaner to the electrical plugs and receptacles. Refer to the manufacturer instructions.
5. Clean the electrical plugs and receptacles.
6. Lightly lubricate the electrical plugs and receptacles with WD-40®.

BATTERY CHARGER



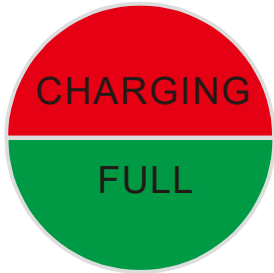

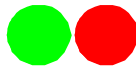

Be familiar with vehicle features before attempting any operations.

CHARGER LED DISPLAY

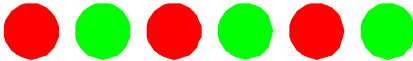

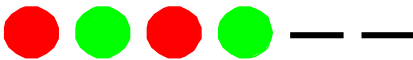
LED LIGHTS		INDICATION
	Red LED light flashing	Charging
	Solid Green light	Charge completely
	Red and Green light flash in order	Refer to the troubleshooting table

LED FAULT CODES

Flashes (" — " means pause 1s)	Cause	Solution
	No load	Check if these happen: the connection of battery and charger is loose, the battery defective, or the battery voltage is too low.
	Over voltage or over current	If the error opens again after restart, return it to factory repair.
	The ambient temperature is too high or too low	Please check if the ambient temperature is too high and if ventilation is good and the position of battery temperature sensor.
	Charger overheating	Please check whether ambient temperature is too high and if ventilation is good.
	Output Under- Voltage	Please return it to the factory. Replace new charger
	Input AC abnormality	Please check the input voltage and the plug poor contact.
	Anyone of the above-mentioned faults repeats five times, then it appears.	Re-up electricity, match the indicator state to the above-mentioned faults then get the corresponding solution.

Be familiar with vehicle features before attempting any operations.

VEHICLE MAINTENANCE

WARNING

UNINTENDED VEHICLE OPERATION CAN CAUSE SERIOUS PERSONAL INJURY OR DEATH. BEFORE LEAVING THE VEHICLE OR DURING VEHICLE MAINTENANCE, DISABLE THE VEHICLE.

ONLY TRAINED TECHNICIANS SHOULD SERVICE OR REPAIR THE VEHICLE. ANYONE DOING EVEN SIMPLE REPAIRS OR SERVICE SHOULD HAVE KNOWLEDGE AND EXPERIENCE IN ELECTRICAL AND MECHANICAL REPAIR. THE APPROPRIATE INSTRUCTIONS MUST BE USED WHEN PERFORMING MAINTENANCE, SERVICE, OR ACCESSORY INSTALLATION. FAILURE TO CORRECTLY MAINTAIN THE VEHICLE AND MAKE NECESSARY REPAIRS CAN DECREASE VEHICLE PERFORMANCE, CAUSE A FIRE, PROPERTY DAMAGE, SERIOUS PERSONAL INJURY, OR DEATH. IF PROBLEMS ARE FOUND DURING SCHEDULED INSPECTION OR SERVICE, OPERATE THE VEHICLE ONLY WHEN REPAIRS ARE MADE.

DO NOT WORK ON THE VEHICLE POWER TRAIN WHEN THE VEHICLE IS LOADED.

DO NOT WEAR LOOSE CLOTHING OR JEWELRY SUCH AS RINGS, WATCHES, CHAINS, ETC., WHEN SERVICING THE VEHICLE OR BATTERY CHARGER. LIFT ONLY ONE END OF THE VEHICLE AT A TIME. USE A SUITABLE LIFTING DEVICE WITH 1000 LB (454 KG) MINIMUM LIFTING CAPACITY. DO NOT USE THE LIFTING DEVICE TO HOLD THE VEHICLE IN THE LIFTED POSITION. USE APPROVED JACK STANDS OF PROPER WEIGHT CAPACITY TO SUPPORT THE VEHICLE AND CHOCK THE WHEELS THAT REMAIN ON THE FLOOR.

IF WIRES ARE REMOVED OR REPLACED, MAKE SURE THAT THE WIRING AND WIRE HARNESS ARE CORRECTLY ROUTED AND ATTACHED. FAILURE TO CORRECTLY ROUTE AND ATTACH THE WIRING COULD RESULT IN VEHICLE MALFUNCTION, PROPERTY DAMAGE, SERIOUS PERSONAL INJURY, OR DEATH.

CAUTION

WEAR SAFETY GLASSES OR APPROVED EYE PROTECTION WHEN YOU DO THE SERVICING OF THE VEHICLE. WEAR RUBBER GLOVES WHEN NEAR THE BATTERY.

LIFT AND LOWER THE VEHICLE

Be familiar with vehicle features before attempting any operations.

LIFT AND LOWER THE VEHICLE

 **WARNING**

LIFTING AND LOWER THE VEHICLE WITH CARGO CAN CAUSE PROPERTY DAMAGED, SERIOUS PERSONAL INJURY, OR DEATH. REMOVE ALL CARGO AND HAVE THE PERSON OUT FROM THE VEHICLE BEFORE THE VEHICLE IS LIFTED.

Steps For Lifting The Vehicle:

- > Before the vehicle is lifted, turn off key switch of the vehicle.
- > Choose the jacks and jack stands rated for the vehicle.
- > Engage the parking brake.
- > Place the jack in the center of the lift point.
- > Lift the front and rear of the vehicle.
- > Put the Jack stands under the frame rails.
- > Lower the vehicle onto the jack stands.

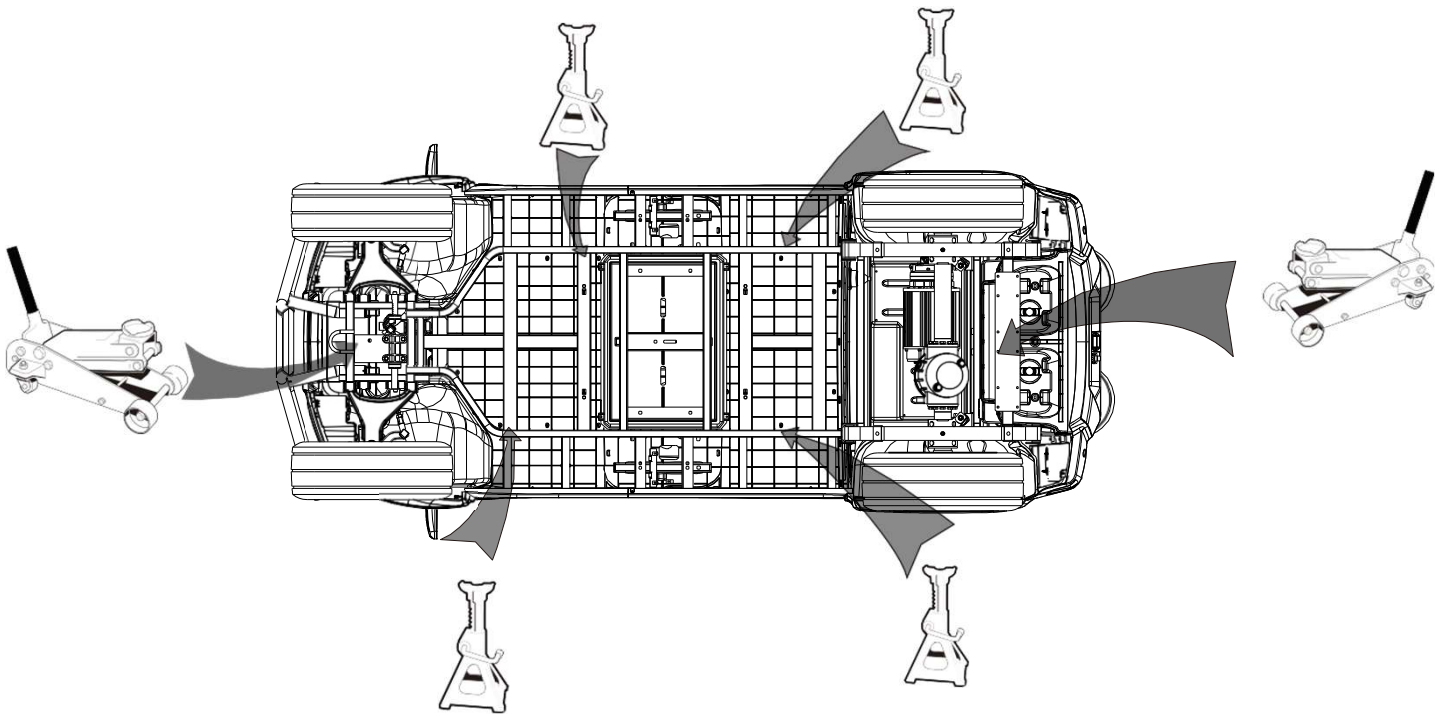

Steps For Lower The Vehicle:

- > Before the vehicle is lowered, turn off key switch of the vehicle.
- > Choose the jacks and jack stands rated for the vehicle.
- > Place the jack in the center of the lift point.
- > Lift the vehicle off from the jack stands.
- > Remove the Jack stands under the frame rails.
- > Lower the vehicle on the ground.
- > Remove the Jacks.

Be familiar with vehicle features before attempting any operations.

VEHICLE SCHEDULED MAINTENANCE CHART

Regular maintenance is required for the best performance and safe operation of the electric vehicle . Periodic maintenance need to perform accordingly .						
1D-per day 1W-per week 1M-per month 1Q-per quarter 1Y-per year						
Item	Descriptions	1D	1W	1M	1Q	1Y
Battery	1.Check the damages may occur on battery surface .		v			
	2.Charge the battery .	v				
	3.Tighten the nut on the battery cable .	v				
	4. Fasten the nut of the battery terminal .		v			
	5.Check whether the battery is over-charged .	v				
	6.Check the SOH (state of health) of the battery .		v			
	7.Check whether the battery is fully charged .	v				
	8.Clean the surface of battery .		v			
Charger	9.Observe the charging status, check if the charger plug becomes hot.	v				
	10.Clean the surface of charger . Do not let water enter into charger .		v			
Motor and controller	11.Check whether all terminals are tightened properly(Turn off the power).			v		
	12.Clean the surface of the controller.				v	
	13.Check whether the solenoid is in order, checking the touching point.					v
	14.Check whether there is water get into motor.	v				
	15.Check whether all the connectors of motor & controller are tightened		v			
	16. Check whether the accelerator pedal works well .	v				
Chassis and body	17.Check whether the brake pedal is firm and can be released freely .			v		
	18.Check whether the brake drum and brake shoe need to be replaced or not				v	
	19.Check the hand break function.			v		
	20.Check the break liquid tank liquid level .			v		
	21.Check tire pressure and tire surface .		v			
	22.Check Whether the shock is leaking or not .			v		
	23.Fasten the bolt of shaft .			v		
	24.Check whether there is sufficient oil inside of rear axle gear box .				v	
	25.Add grease to front hub and steering gear box .				v	
	26. Adjust the front and rear suspension .				v	
27.Clean the body and seat .	v					

NOTICE

The Maintenance Service Schedule must be done more frequently on vehicles that are constantly subjected to heavy use or severe operating conditions.

Be familiar with vehicle features before attempting any operations.

CHASSIS MAINTENANCE

Check the tires every time one uses the vehicle, remove embedded objects or metal items away from tire surface. If the tire have embedded objects on surface, it will lead to excessive noises from tire while driving or tire air leakage.

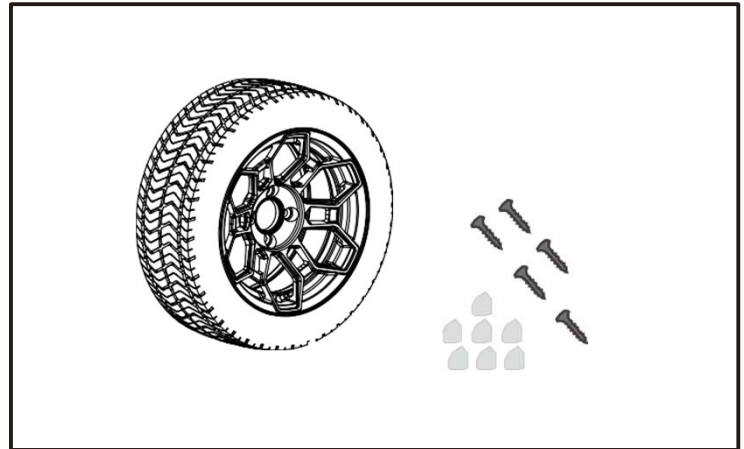

Check the tires every time one uses the vehicle. the tires should be inflated with sufficient air. The air pressure should with normal level . Check the tire chapter for more specific information of tire inflation.

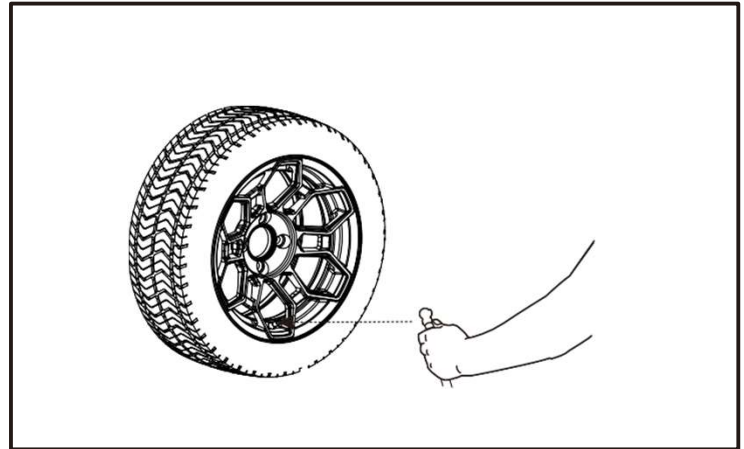

DANGER

FLAT TIRE MAY CAUSE UNSTABLE STEERING FUNCTION WHILE DRIVING.

Add lubricant to mechanical joint parts , the vehicle should be kept in good turning and operating functions. To acquire that one should add lubricant to needed parts every one month.

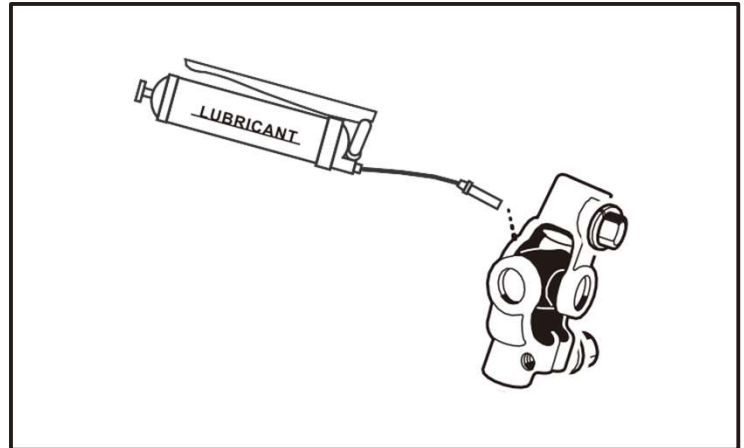

Check the dust-proof cover on steering gear box, the covers are supposed to be tightened on the two terminal ends . Loose cover will let water and dust into the gear box, cause the gears rusting .

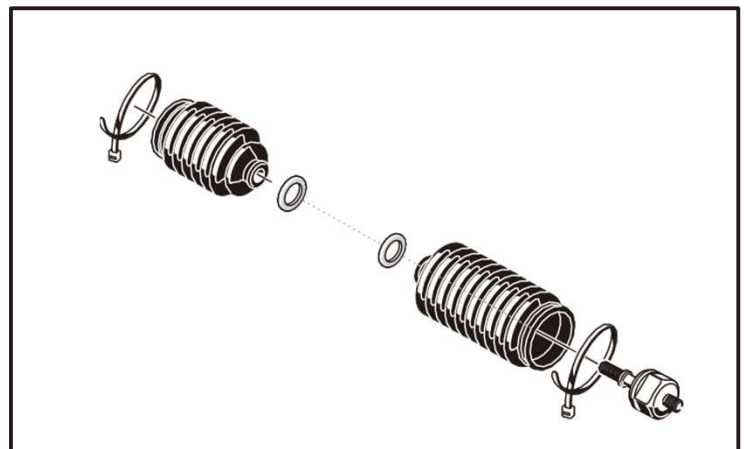

Be familiar with vehicle features before attempting any operations.

Check the gear oil capacity of rear axle.

 CAUTION

Low gear oil capacity may cause damages to rear axle cams or excessive noises.

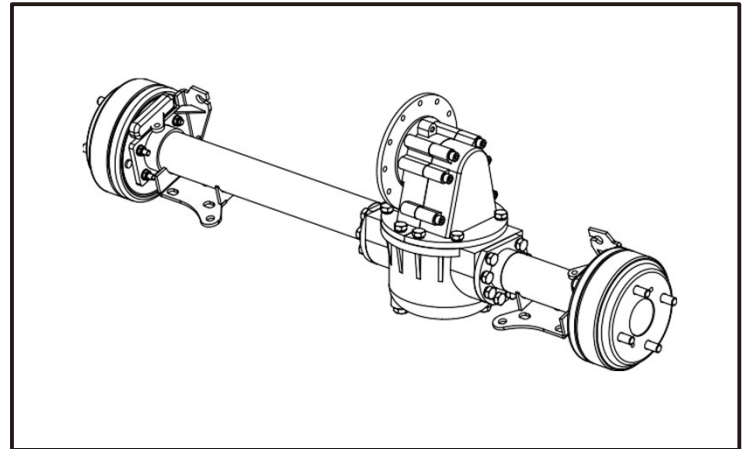

Check the brake shoes worn out conditions, if it is extremely worn out(1/3 left) ,then the brake shoes need to be replaced with a new one.

 DANGER

Do not drive the vehicle with poor brakes.

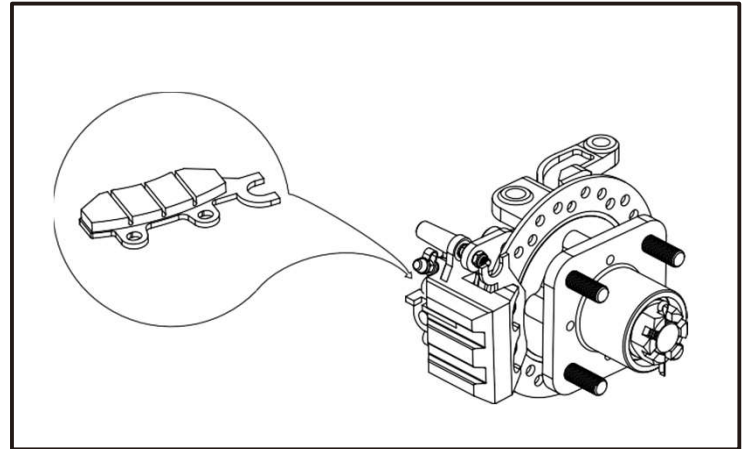

Check the brake fluid level(The oil tank located inside the front trunk, remove the rubber pad to get access to it) , make sure the brake fluid is sufficient and clean without foreign objects mixed in the fluid.

 DANGER

Do not drive the vehicle with insufficient brake fluid.

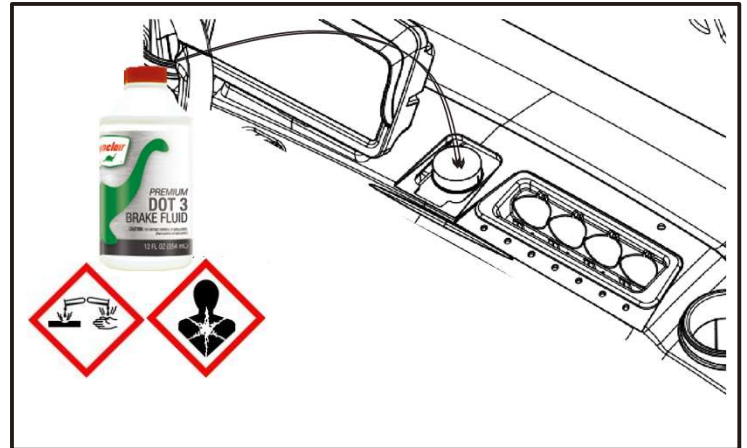

Change the button cell battery every 1-2 years(remove the 4 bolts on the key FOB to dismantle the covers to access the button cell battery) .

 CAUTION

Do not throw battery in fire.

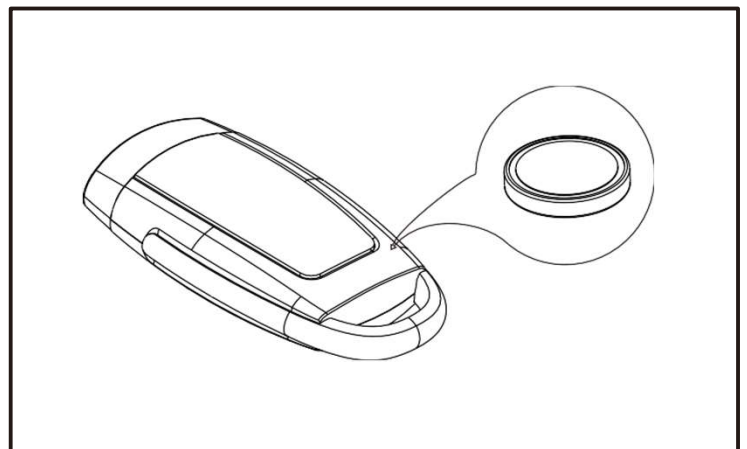

Be familiar with vehicle features before attempting any operations.

VEHICLE MAINTENANCE



WARNING

MOISTURE CAN CAUSE ELECTRICAL COMPONENT DAMAGE. DO NOT USE A PRESSURE WASHER OR STEAM CLEANER TO CLEAN THE VEHICLE ELECTRICAL SYSTEM. OTHERWISE IT WILL CAUSE ELECTRICAL FAILURE PERMANENTLY.

Pre-operation before cleaning the vehicle:

1. Move the vehicle on a solid flat ground.
 2. Apply the parking brake.
 3. Turn the key switch to OFF
 4. Remove the key.
 5. Place the DNR switch to N.
- Use only commercially available automotive cleaners with a sponge or soft cloth for normal cleaning. A garden hose at normal residential water pressure is sufficient.
 - Use a commercially available aluminum cleaner paste and fine grade (No. 00) steel wool to remove oxidation or discoloration from aluminum.
 - Use non-abrasive wax products. Fertilizers, asphalt, creosote, paint, or chewing gum should be removed immediately to prevent possible stains.
 - The seats of the vehicle will last longer with proper cleaning. Use a solution of 10% liquid soap and warm water applied with a soft cloth. Use a soft bristle brush to remove embedded dirt.
 - Use mild soapy water and a micro-fiber cloth to clean the windshield to minimize the risk of scratching. Avoid using glass cleaners or paper towels as these increase the chances of scratching or scuffing the windshield.

Be familiar with vehicle features before attempting any operations.

JOBS TO BE DONE PRIOR TO THE STORAGE

- >Put golf cart under shelter,keep the golf cart in dry and ventilated space.Optimal temperature 14°F to 95°F(-10°C to 35°C).Maximum storage temperature should not be higher than 122°F(50°C).
- >Turn the key switch to the OFF position,remove the key and leave the forward/reverse switch in the NEUTRAL position during storage.
- >Power down all accessories.
- >Clean the battery packs,tops and terminals using a battery acid neutralizer(1 cup baking soda per 1 gallon water).Check,clean and treat battery terminal connections with a battery terminal protector spray.
- >Disconnect batteries per ensuring that the cables do not come into contact with a terminal (Disconnect the 48V Main power outlet cables from battery pack,insulate the cable).
- >Connect Battery cables back to system,charge the battery to full state every 1-3 months to keep battery alive without damages caused by over-discharging.
- >Perform all semi-Annual Lubrications.
- >Thoroughly clean the front and rear body,seats,battery compartment and underside of the vehicle.
- >DO NOT engage the park brakes,but secure the golf cart from rolling.Check the wheels with wheel stopper or something similar.
- >Check Tire pressure and inflate the tires to standard pressure level as values presented on tires.
- >Thoroughly clean the front and rear body,seats,battery compartment and underside of the vehicle.

BRING THE VEHICLE BACK TO SERVICE FROM STORAGE

- 1.Fully charge the battery.
- 2.Set the Forward /Reverse control(DNR)to N.
- 3.Adjust the pressure in each tire to the recommended tire pressure.
4. Have a trained technician lubricate the vehicle.
- 5.Do a daily pre-operation safety checklist.
- 6.Do a vehicle performance inspection.

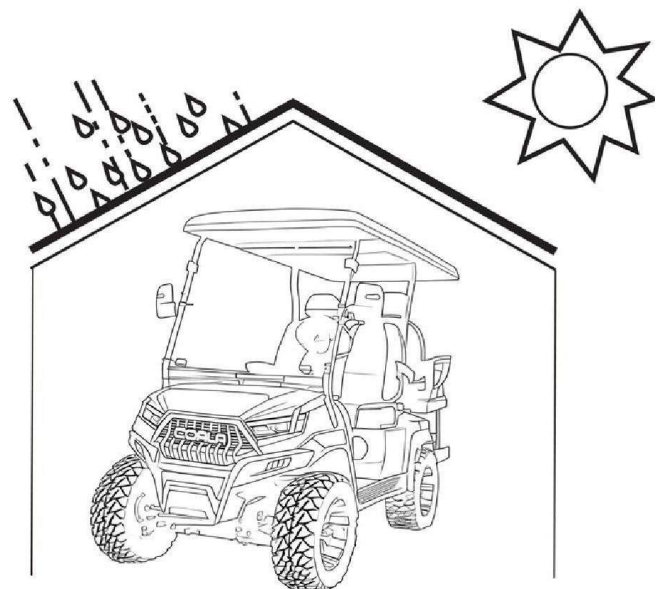
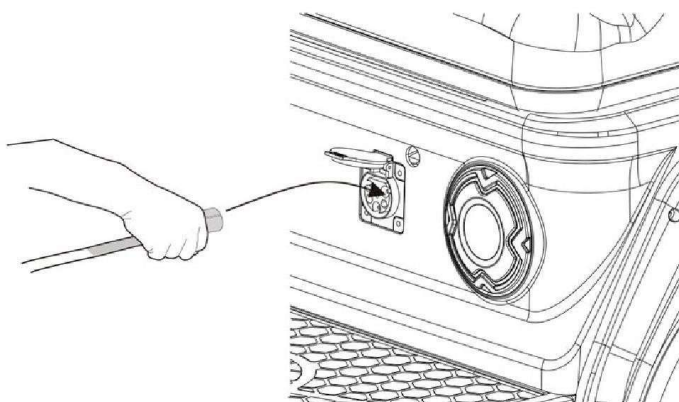

Be familiar with vehicle features before attempting any operations.

VEHICLE TRANSPORTATION AND TOWING

WARNING

DO NOT RIDE ON OR ALLOW OTHER PEOPLE ON A VEHICLE BEING TRANSPORTED ON A TRAILER OR BEING TOWED WITH ANOTHER VEHICLE.

DO NOT CARRY PASSENGERS ON GOLF CART WHILE TOWING THE VEHICLE.

APPLY BRAKE TO LIMIT SPEED WHEN COMMIT SHARP TURNS.

APPLY BRAKE TO LIMIT SPEED WHEN TOW THE GOLF CART ON UNEVEN TERRAIN.

TURN ON THE HAZARD LIGHTS IF VEHICLE WAS CONFIGURED WITH.

SECURE THE SEATS/WHINSHIELD /OTHER LOOSE ITEMS BEFORE TOWING GOLF CART.

DO NOT TOW MULTIPLE GOLF CARTS IN SERIES FORMATION.

DO NOT TOW THE GOLF CART ON HIGHWAY ROADS.

ABORT TOWING WHEN ABNORMAL PHENOMENONS BEING DETECTED.

The following steps can help you to tow an COALA golf cart safely without any damage.

Turn off key switch.

Keep the Forward/Reverse switch in a neutral position.

If you need to tow the golf cart for long distance ,remove the battery connections from battery pack terminals. This is done to ensure that the Rear axle/Motor/Controller/Batteries do not get damaged during the towing process.

Move the golf cart at a slower speed (Optimally Between 5-15MPH)or the same speed that you would generally move it if it has power. Exceeding the speed limit can over-spin the motor and ruin it.

Pulling your golf cart faster than designed to go can over-spin the motor. Possible slinging the internal parts into pieces and ruining the motor.

Unlock the EM brake on your golf cart motor, make sure to **unlock it mechanically before towing the golf cart.**

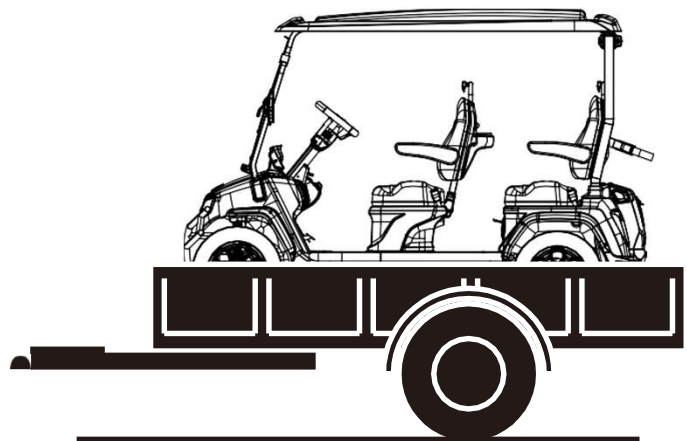
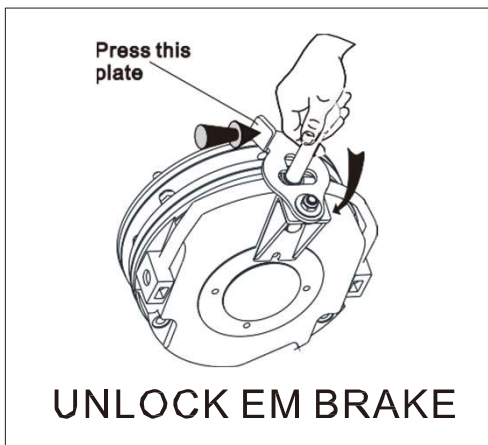

VEHICLE GENERAL SPECIFICATION

Be familiar with vehicle features before attempting any operations.

VEHICLE GENERAL SPECIFICATIONS

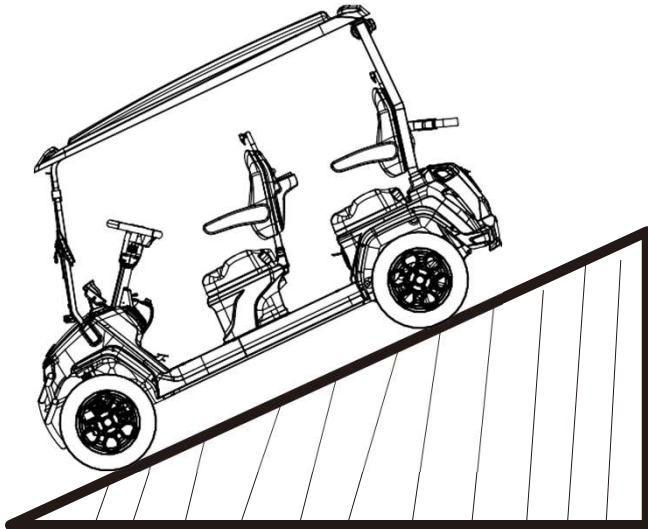

**Recommended Max Ramp
25% Grade**

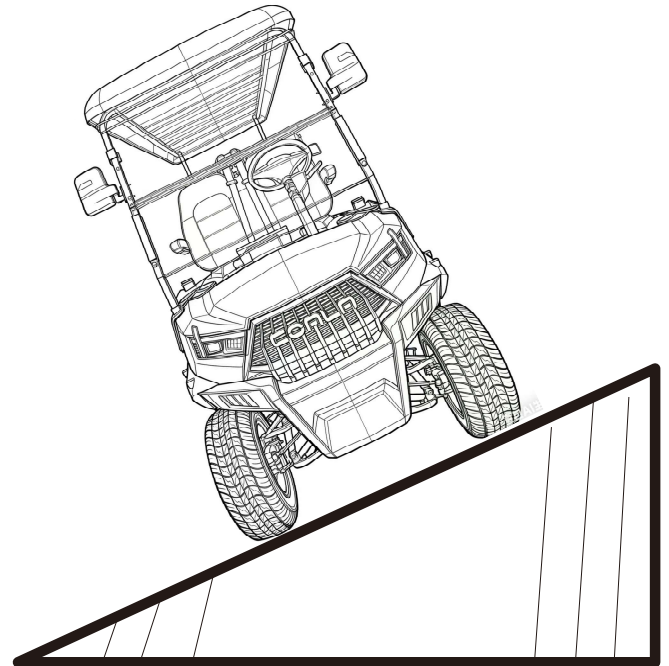

**Recommended Max Side Tilt
25% Grade**

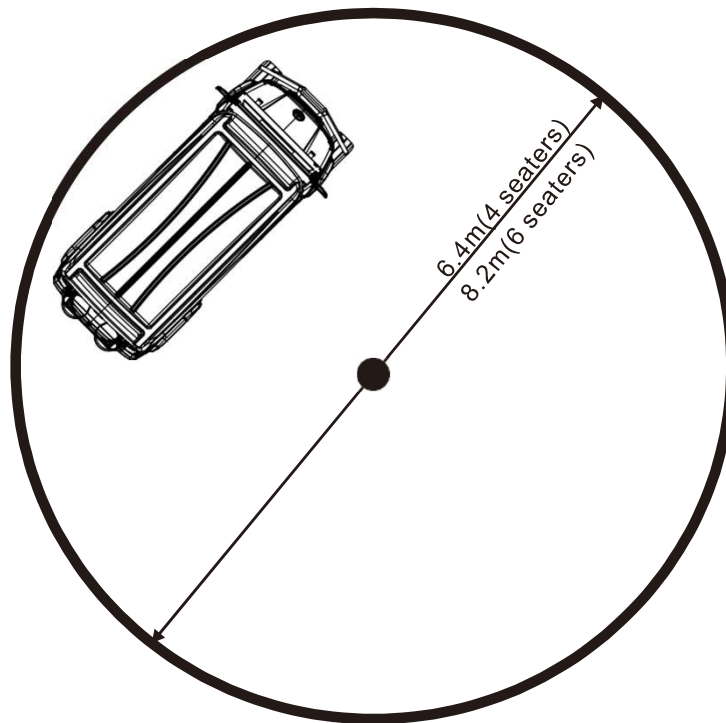

Vehicle Turning Clearance Diameter



COALA ELECTRIC VEHICLES INC
Address: 9109 Santa Anita Ave, Rancho
Cucamonga, CA 91730
TEL: +1(626)988-6768
+1(949)696-7162
Email: cabaseoffice@gmail.com
www.drivecoala.com